

Interface Selection Guide

4Q 2006



LVDS

Digital Isolators

RS-485/422

RS-232

UARTs

CAN

SerDes

DVI/PanelBus™

TMDS

FlatLink™ 3G

Clock Distribution

VME

GTLP

1394

CardBus

PCIe/PCI

USB



Table of Contents



Check interface.ti.com for the latest IBIS Models and evaluation modules (EVMs).

Introduction	3
LVDS, xECL, CML	4
Multipoint-LVDS (M-LVDS)	8
Digital Isolators	10
RS-485/422	11
RS-232	13
UARTs	16
CAN	18
FlatLink™ 3G	19
SerDes (Serial Gigabit Transceivers and LVDS)	20
DVI/PanelBus™	22
TMDS	24
USB Hub Controllers and Peripheral Devices	25
USB Port Protection	26
USB Power Managers	27
PCI Express®	29
PCI Bridges	33
CardBus Power Switches	34
1394 (FireWire®)	36
GTL	39
VME	41
Clock Distribution Circuits	42
Cross-Reference Guide	43
Device Index	47
Technical Support	48



Texas Instruments (TI) provides complete interface solutions that empower you to differentiate your products and accelerate time-to-market. Our expertise in high-speed, mixed-signal circuits, system-on-a-chip integration and advanced product development processes ensures you will receive the silicon, support tools, software and technical documentation to create and deliver the best products on time and at competitive prices. Included in this selection guide you will find design considerations, technical overviews, graphic representation of portfolios, parametric tables and resource information on the following families of devices:

LVDS: (p. 4) TIA/EIA-644A specification designed for differential transmission delivering signaling rates into the Gbps range and power in the mW range with low EMI to the telecommunication and consumer markets.

xECL: (p. 4) Emitter coupled logic (xECL), high-speed differential interface technology designed for low jitter and skew.

CML: (p. 4) Current-mode logic (CML), high speed differential interface technology.

M-LVDS: (p. 8) TIA/EIA-899 specification with all the benefits of LVDS applicable to multi-point bus architecture in backplanes. Used often for clock distribution, e.g. AdvancedTCA.

Digital Isolators: (p. 10) The new ISO72x high-speed digital isolators use state-of-the-art integrated capacitive coupling and silicon-dioxide isolation barrier to provide up to 150-Mbps signaling rate with only 1-ns jitter, best-of-class noise immunity and high reliability.

RS-485/422: (p. 11) Robust TIA/EIA-485 and TIA/ EIA-422 specifications specially designed for harsh, industrial environments transmitting a differential signal up to 50 Mbps or 1.2 km.

RS-232: (p. 13) TIA/EIA-232 specification defining single-ended interface between data terminal equipment (DTE) and data circuit-terminating equipment (DCE).

UARTs: (p. 16) Universal Asynchronous Receiver/Transmitters are the key logic component of serial communication utilizing RS232, RS485/422 or LVDS transceivers to transmit or receive between remote devices performing parallel to serial conversion in the transmit process and serial to parallel conversion in the receive process.

CAN: (p. 18) Controller Area Network (ISO11898) specification commonly used in automotive and industrial applications describes differential signaling at a rate up to 1 Mbps on a 40-meter bus with multipoint topology.

FlatLink™ 3G: (p. 19) A new family of serializers and deserializers designed for mobile phone displays.

SerDes: (p. 20) Serializers and deserializers in the gigabit range designed to bridge large numbers of data bits over a small number of data lines in telecommunication applications.

DVI/PanelBus™: (p. 22) The Digital Visual Interface Specification, DVI, is an industry standard developed by the Digital Display Working Group (DDWG) for high-speed digital connection to digital displays. DVI uses transition-minimized DC balanced (TMDS) data signaling.

TMDS: (p. 24) Transition minimized differential signaling is the electrical interface used by DVI and HDMI.

USB Hub Controllers and Peripheral Devices: (p. 25) The USB standard was established to make connecting PCs, peripherals and consumer electronics flexible and easy. The hub controller manages USB port connect/disconnect activities and a peripheral controller enables USB connectivity of a peripheral device to either a host or hub.

USB Port Protection: (p. 26) Transient voltage suppressor protects USB 1.1 devices from ESD and electrical noise transients.

USB Power Managers: (p. 27) TI products, like TPS204xA and TPS205xA, are designed to meet all the USB 1.0 and 2.0 requirements for current-limiting and power switching to reliably control the power on the voltage bus.

PCI Express®: (p. 29) A robust, scalable, flexible and cost-effective I/O interconnect.

PCI Bridges: (p. 33) A peripheral component interconnect (PCI) bridge provides a high-performance connection path between either two PCI buses or a PCI component and one or more DSP devices.

CardBus Power Switches: (p. 34) The CardBus controller uses the card detect and voltage sense pins to determine a PC card's voltage requirements and then directs the PCMCIA power switch to enable the proper voltages. Standard PC cards require that V_{CC} be switched between ground, 3.3 V, and 5 V, while VPP is switched between ground, 3.3 V, 5 V, and 12 V. CardBay sockets have the standard requirements for V_{CC} , but require ground, 3.3 V, and 5 V to VPP, and ground, 1.8 V, or 3.3 V to V_{CORE} . Other PC card applications may simply not need 12 V or VPP while still having the standard requirements for V_{CC} . Therefore, consider the voltage requirements of the application when selecting a PCMCIA power switch.

1394: (p. 36) IEEE 1394 (FireWire®) high-speed interconnection enables simple, low-cost, high-bandwidth, real-time data connectivity between computers, peripherals and consumer electronics.

GTLP: (p. 39) Gunning transceiver logic plus (GTLP) derived from the JEDEC JESD8-3 GTL standard is a reduced-voltage-swing technology designed for high-speed interface between cards operating at LVTTTL logic levels and backplanes operating at GTLP signal levels.

VME: (p. 41) The VMEbus™ is a standardized, 64-bit, backplane architecture that is coordinated and controlled by VITA. VME is used extensively in military, industrial and aerospace applications.

Clock Distribution Circuits: (p. 42) TI offers both single-ended and differential clock buffers that perform from below 200 MHz up to 3.5 GHz in a variety of fan-out options. In addition to simple option for customers needing differential signals (LVPECL) and single-ended signals (LVTTTL/LVCMOS) from the same device.



Design Considerations

Signaling Rate — TI offers repeaters/translators and crosspoint switches with signaling rates up to 4.0 Gbps.

Jitter — Reducing jitter, the deviation of a signal timing event from its ideal position, has become a priority for ensuring reliability in high-speed data buses.

Skew — Excessive skew, the time delta between the actual and expected arrival

time of a clock signal, can limit the maximum bandwidth performance and lead to data sampling errors. Low skew specifications make high-speed interconnect devices excellent for signal buffering.

Power Consumption — Low-voltage differential signaling (LVDS) offers a low-power alternative to ECL and PECL devices. Current-mode drivers in LVDS produce a constant current, which allows power consumption to be relatively independent of frequency. The

constant current driver delivers about 3.5 mA to a 100-Ω load.

Technical Information

- LVDS is based on the TIA/EIA-644A standard conceived to provide a general-purpose electrical-layer specification for drivers and receivers connected in a point-to-point or multidrop interface.

LVDS Family of Products

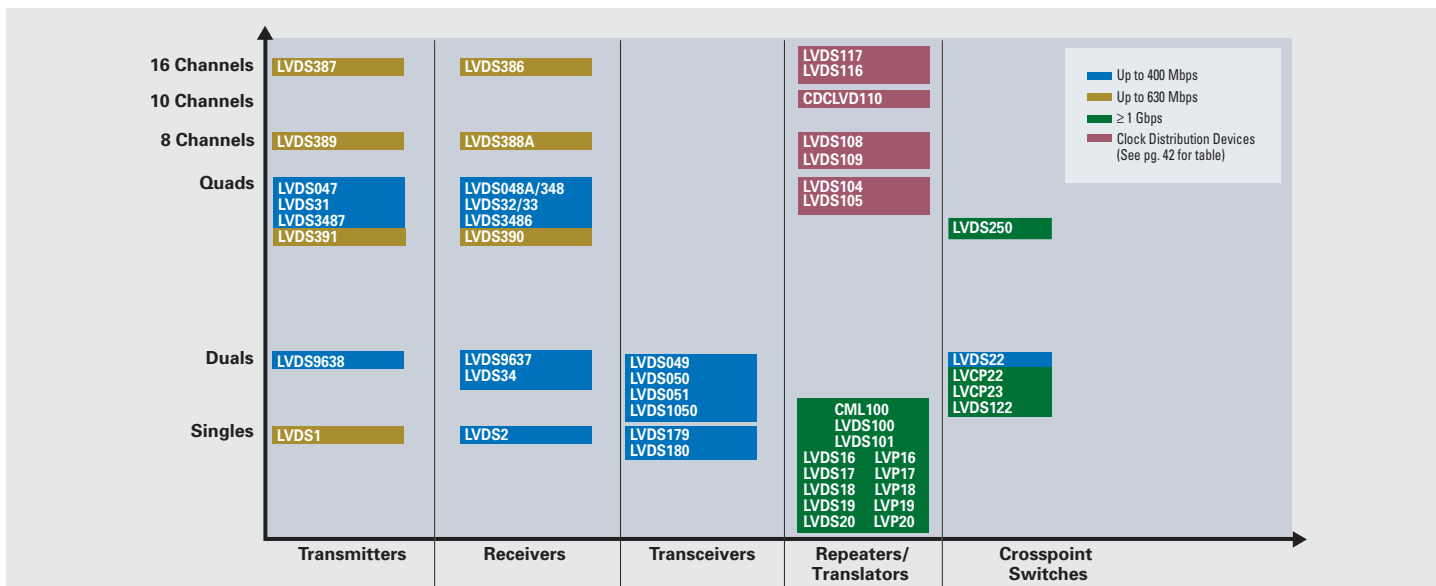

Resources For a complete list of resources (evaluation modules, data sheets and application notes), visit interface.ti.com

Literature Number	Description
Application Notes	
SLLA014A	Low-Voltage Differential Signaling (LVDS) Design Notes (Rev. A)
SLLA030C	Reducing Electromagnetic Interference with LVDS (Rev. C)
SLLA031A	Using an LVDS Receiver with TIA/EIA-422 Data (Rev. A)
SLLA034A	Slew Rate Control of LVDS Circuits (Rev. A)
SLLA038B	Interface Circuits for TIA/EIA-644 (LVDS) (Rev. B)
SLLA053B	Performance of LVDS with Different Cables (Rev. B)
SLLA054A	LVDS Multidrop Connections (Rev. A)
SLLA065	A Comparison of LinBiCMOS and CMOS Process Technologies in LVDS ICs
SLLA082B	Active Fail-Safe in TI's LVDS Receivers (Rev. B)
SLLA100	Increase Current Drive Using LVDS
SLLA101	Interfacing Different Logic with LVDS Receivers
SLLA103	LVPECL and LVDS Power Comparison
SLLA104	Suggestions for LVDS Connections
SLLA105	DSP to DSP Link Using LVDS
SLLA107	Live Insertion with Differential Interface Products
SLLA147	Suitable LVDS Architectures

Literature Number	Description	
Application Notes		
SCAA059	AC-Coupling Between Differential LVPECL, LVDS, HSTL, and CML	
SCAA062	DC-Coupling Between Differential LVPECL, LVDS, HSTL, and CML	
Part Number	Description	Price*
Evaluation Modules (EVMs)		
SN65LVDS31-32EVM	Evaluation Module for LVDS31 and LVDS32	49.00
SN65LVDS31-32BEVM	Evaluation Module for LVDS31 and LVDS32B	49.00
SN65LVDS31-33EVM	Evaluation Module for LVDS31 and LVDS33	49.00
SN65LVDS386EVM	SN65LVDS386 Evaluation Module	49.00
SN65LVDS387EVM	SN65LVDS387 Evaluation Module	49.00
SN65LVDS100EVM	SN65LVDS100 Evaluation Module	99.00
SN65LVDS20EVM	SN65LVDS20 Evaluation Module	49.00
SN65CML20EVM	SN65CML20 Evaluation Module	49.00
SN65LVCP22-23EVM	SN65LVCP22 Evaluation Module	25.00
SN65LVDS122EVM	SN65LVDS122 Evaluation Module	49.00
SN65LVDS250EVM	SN65LVDS250 Evaluation Module	49.00

Note: IBIS models are available at interface.ti.com

*Suggested resale price in U.S. dollars.



LVDS/LVPECL/CML Repeaters/Translators and Crosspoints Selection Guide

Device ¹	Description	No. of Tx	No. of Rx	Input Signal	Output Signal	Signaling Rate (Mbps)	Jitter Max (ps)	Part-to-Part Skew Max	Tx tpd Typ (ns)	Rx tpd Typ (ns)	I _{CC} Max (mA)	ESD HBM (kV)	Pin/Package(s)	Price*
Crosspoint Switch Family														
SN65LVCP22	2X2 Crosspoint Switch: LVDS Outputs	2	2	LVPECL, LVDS, CML	LVDS	1000	105	100	0.65	0.65	85	5	16SOIC, 16TSSOP	2.70
SN65LVCP23	2X2 Crosspoint Switch: LVPECL Outputs	2	2	LVPECL, LVDS, CML	LVPECL	1300	100	100	0.65	0.65	65	5	16SOIC, 16TSSOP	5.20
SN65LVCP40	Dual 1:2 Mux with Equalizer and Pre-Emphasis	6	6	LVPECL, LVDS, CML	CML	4000	30	500	1	1	254	4	48QFN	17.40
SN65LVDS122 ²	2X2 Crosspoint Switch: LVDS Output	2	2	LVPECL, LVDS, CML	LVDS	1500	65	150	0.9	0.9	100	4	16SOIC, 16TSSOP	4.75
SN65LVDS250²	4X4 Crosspoint Switch: LVDS Output	4	4	LVPECL, LVDS, CML	LVDS	2000	50	150	0.9	0.9	145	3	TSSOP	7.75
Repeaters/Translators														
SN65CML100	LVDS/LVPECL/CML-to-CML Repeater/Translator	1	1	LVPECL, LVDS, CML	CML	1500	70	100	0.8	—	12	5	8SOIC, 8VSSOP	2.55
SN65LVDS100 ²	LVDS/LVPECL/CML to LVDS Repeater/Translator	1	1	LVPECL, LVDS, CML	LVDS	2000	65	100	0.8	—	30	5	8SOIC, 8VSSOP	2.55
SN65LVDS101 ²	LVDS/LVPECL/CML-to-LVPECL Repeater/Translator	1	1	LVPECL, LVDS, CML	LVPECL	2000	65	100	0.9	—	90	5	8SOIC, 8VSSOP	2.55
SN65LVDS16/17	2.5-V/3.3-V Oscillator Gain Stage/Buffer (single ended/diff inputs)	1	1	LVPECL	LVDS	2000	10	130	0.63	—	48	2	8QFN	2.55
SN65LVDS18/19	2.5-V/3.3-V Oscillator Gain Stage/Buffer (single ended/diff inputs)	1	1	LVPECL	LVDS	1000	10	130	0.63	—	36	2	8QFN	1.95
SN65LVDS20	2.5-V/3.3-V LVDS repeater with enable	1	1	LVPECL, LVDS, CML	LVDS	4000	45	130	0.63	—	45	3	8QFN	3.30
SN65LVP16/17	2.5-V/3.3-V Oscillator Gain Stage/Buffer (single ended/diff inputs)	1	—	LVPECL	LVPECL	2000	10	130	0.63	—	30	2	8QFN	2.55
SN65LVP18/19	2.5-V/3.3-V Oscillator Gain Stage/Buffer (single ended/diff inputs)	1	—	LVPECL	LVPECL	1000	10	130	0.63	—	20	2	8QFN	1.95
SN65LVP20	2.5-V/3.3-V LVPECL	1	1	LVPECL, LVDS, CML	LVPECL	4000	10	130	0.63	—	45	3	8QFN	4.40

¹Supply voltage for all devices listed above is 3.3 V. ²Integrated termination available (100-Ω)-SN65LVDTxxx.

*Suggested resale price in U.S. dollars in quantities of 1,000.

New products are listed in bold red.

PECL Selection Guide

Device	Description	No. of Tx	No. of Rx	Input Signal	Output Signal	Signaling Rate (Mbps)	Tx tpd Typ (ns)	Rx tpd Typ (ns)	I _{CC} Max (mA)	ESD HBM (kV)	Supply Voltage (V)	Pin/Package(s)	Price*
TB5D1M	Replacement for Agere BDG1A & BPNGA, built-in surge protection	4	—	TTL	PECL	400	1.2	—	40	3	3.3, 5	16SOIC gull-wing, 16SOIC	7.20
TB5D2H	Replacement for Agere BDG1A & BDGLA, power down open circuit o/p	4	—	TTL	PECL	400	1.2	—	40	3	3.3, 5	16SOIC gull-wing, 16SOIC	7.20
TB5R1	Replacement for Agere BRF1A & BRF2A, 8KΩ Input Impedance	—	4	PECL	TTL	400	—	2.5	32	3	5	16SOIC gull-wing, 16SOIC	7.20
TB5R2	Replacement for Agere BRS2A & BRS2B	—	4	PECL	TTL	400	—	2.5	32	3	5	16SOIC gull-wing, 16SOIC	7.20
TB5R3	Replacement for Agere BRF1A	—	4	LVPECL	TTL	400	—	2.6	50	3	5	16SOIC gull-wing, 16SOIC	8.65
TB3R1	3.3-V supply alternative to Agere BRF1A & BRF2A	—	4	LVPECL	LVTTTL	400	—	—	32	3	3.3	16SOIC	8.65
TB3R2	3.3-V supply alternative to Agere BRS2A & BRS2B	—	4	LVPECL	LVTTTL	400	—	—	32	3	3.3	16SOIC	8.65
TB5T1	Dual differential transceiver	2	2	LVPECL, LVTTTL	LVPECL, LVTTTL	400	1.2	2.5	35	3	5	8SOIC gull-wing, 8SOIC	7.20
SN65LVDS33	Receiver with -4 V to 5 V Common-Mode Range, LVDS32 Footprint	—	4	LVDS, LVPECL, PECL, LVECL, ECL	LVTTTL	400	—	4	23	15	3.3	16SOIC, 16TSSOP	1.60
SN65LVDS348 ¹	Receiver with -4 V to 5 V Common-Mode Range, LVDS48 Footprint	—	4	LVDS, LVPECL, PECL, LVECL, ECL	LVTTTL	340	—	6	20	15	3.3	16SOIC, 16TSSOP	1.60
SN65LVDS34 ¹	Receiver with -4 V to 5 V Common-Mode Range	—	2	LVDS, LVPECL, PECL, LVECL, ECL	LVTTTL	400	—	4	12	15	3.3	8SOIC	1.15
SN65LVDS352 ¹	Receiver with -4 V to 5 V Common-Mode Range	—	4	LVDS, LVPECL, PECL, LVECL, ECL	LVTTTL	560	—	6	20	15	3.3	24TSSOP	1.80

¹Integrated Termination Available (100-Ω)-SN65LVDTxxx.

*Suggested resale price in U.S. dollars in quantities of 1,000.



LVDS Selection Guide

Device	Description	No. of Tx	No. of Rx	Input Signal	Output Signal	Signaling Rate (Mbps)	Part-to-Part Skew Max (ps)	Tx tpd Typ (ns)
Single								
SN65LVDS1	Driver	1	—	LVTTTL	LVDS	630	—	1.7
SN65LVDS2 ¹	Receiver	—	1	LVDS	LVTTTL	400	—	1.7
SN65LVDS179	Full-Duplex Transceiver, No Enables	1	1	LVDS, LVTTTL	LVTTTL, LVDS	400	—	1.7
SN65LVDS180	Full-Duplex Transceiver, with Enables	1	1	LVDS, LVTTTL	LVTTTL, LVDS	400	—	1.7
Dual								
SN65LVDS9638	Driver	2	—	LVTTTL	LVDS	400	800	1.7
SN65LVDS9637	Receiver	—	2	LVDS	LVTTTL	400	1000	—
SN65LVDS049	Transceiver, Driver and Receiver Enable	2	2	LVDS, LVTTTL	LVTTTL, LVDS	400	100	1.3
SN65LVDS050	Transceiver, Driver and Receiver Enable	2	2	LVDS, LVTTTL	LVDS, LVTTTL	400	—	1.7
SN65LVDS051	Transceiver, Driver Enable Only	2	2	LVDS, LVTTTL	LVDS, LVTTTL	400	—	1.7
SN65LVDS1050	Transceiver with 2.7-V Supply	2	2	LVDS, LVTTTL	LVTTTL, LVDS	400	—	1.7
SN65LVDS22	Multiplexed LVDS Repeater	2	2	LVDS	LVDS	250	—	4
Quad								
SN65LVDS047	Driver with Flow-Through Pinout	4	—	LVTTTL	LVDS	400	1000	1.8
SN65LVDS31	Driver, AM26LS31 Footprint	4	—	LVTTTL	LVDS	400	800	1.7
SN65LVDS3487	Driver, MC34987 Footprint	4	—	LVTTTL	LVDS	400	800	1.7
SN65LVDS391	Driver with Flow-Through Pinout	4	—	LVTTTL	LVDS	630	1500	1.7
SN65LVDS048A	Receiver with Flow-Through Pinout	—	4	LVDS	LVTTTL	400	1000	—
SN65LVDS32	Receiver, AM26LS32 Footprint	—	4	LVDS	LVTTTL	400	1000	—
SN65LVDS3486	Receiver, MC3486 Footprint	—	4	LVDS	LVTTTL	400	1000	—
SN65LVDS390 ¹	Receiver with Flow-Through Pinout	—	4	LVDS	LVTTTL	630	1000	—
8-Channel								
SN65LVDS389	Driver	8	—	LVTTTL	LVDS	630	1500	1.7
SN65LVDS388A ¹	Receiver	—	8	LVDS	LVTTTL	630	1000	—
16-Channel								
SN65LVDS387	Driver	16	—	LVTTTL	LVDS	630	1500	1.7
SN65LVDS386 ¹	Receiver	—	16	LVDS	LVTTTL	630	1000	—

¹Integrated termination available (100-Ω) - SN65LVDTx.



LVDS Selection Guide

Device	Rx tpd Typ (ns)	I _{cc} Max (mA)	ESD HBM (kV)	Supply Voltage (V)	Pin/Package(s)	Price*
Single Family						
SN65LVDS1	—	8	15	3.3	8SOIC, 5SOP	0.47
SN65LVDS2 ¹	2.6	7	15	3.3	8SOIC, 5SOP	0.47
SN65LVDS179	3.7	12	12	3.3	8SOIC, 8VSSOP	1.35
SN65LVDS180	3.7	12	12	3.3	14SOIC, 14TSSOP	1.35
Dual Family						
SN65LVDS9638	—	13	8	3.3	8HTSSOP, 8SOIC, 8VSSOP	1.15
SN65LVDS9637	2.1	10	8	3.3	8HTSSOP, 8SOIC, 8VSSOP	1.15
SN65LVDS049	1.9	35	10	3.3	16TSSOP	1.00
SN65LVDS050	3.7	20	12	3.3	16SOIC, 16TSSOP	2.00
SN65LVDS051	3.7	20	12	3.3	16SOIC, 16TSSOP	2.00
SN65LVDS1050	3.7	20	12	2.7	16TSSOP	2.00
SN65LVDS22	4	20	12	3.3	16SOIC, 16TSSOP	2.80
Quad Family						
SN65LVDS047	—	26	8	3.3	16SOIC, 16TSSOP	1.30
SN65LVDS31	—	35	8	3.3	16SOIC, 16TSSOP, 16SOP	1.50
SN65LVDS3487	—	35	8	3.3	16SOIC	1.50
SN65LVDS391	—	26	15	3.3	16SOIC, 16TSSOP	1.50
SN65LVDS048A	2.4	15	10	3.3	16SOIC, 16TSSOP	1.30
SN65LVDS32	2.1	18	8	3.3	16SOIC, 16TSSOP, 16SOP	1.50
SN65LVDS3486	2.1	18	8	3.3	16SOIC	1.50
SN65LVDS390 ¹	2.5	18	15	3.3	16SOIC, 16TSSOP	1.50
8-Channel Family						
SN65LVDS389	—	70	15	3.3	38TSSOP	2.90
SN65LVDS388A ¹	2.5	40	15	3.3	38TSSOP	2.90
16-Channel Family						
SN65LVDS387	—	95	15	3.3	64TSSOP	5.55
SN65LVDS386 ¹	2.5	70	15	3.3	64TSSOP	5.55

¹Integrated termination available (100-Ω)-SN65LVDTx

*Suggested resale price in U.S. dollars in quantities of 1,000.



M-LVDS Features

- TIA/EIA-899 standard
- Driver output current
 - 11.3 mA vs. 3.5 mA (LVDS)
- Receiver thresholds
 - 50 mV vs. 100 mV (LVDS)
- Driver edge rate control
 - 1 ns min allows ease-of-stub design
- Contention provisions
 - Driver short circuit limited to 43 mA
 - Drivers, receivers and disabled devices must limit their bus voltage from 0 to 2.4 V
 - Drivers are tested with 32 contending nodes

M-LVDS Devices from TI

- TIA/EIA-899 standard compliant guarantees true multipoint
- Type 1 receivers: 25-mV hysteresis to prevent oscillation
- Type 2 receivers: internal failsafe (no external bias network)
- -1-V to 3.4-V common mode
- 3.3-V supply operation

M-LVDS for ATCA

- Synchronous ATCA clock signals (8 kHz, 19.22 MHz and user defined <100 MHz) use M-LVDS.

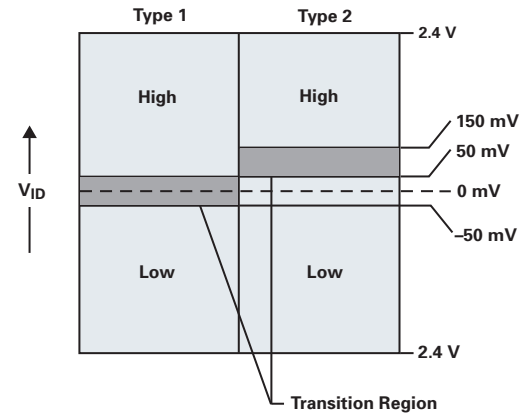

Receiver types.

Multipoint LVDS

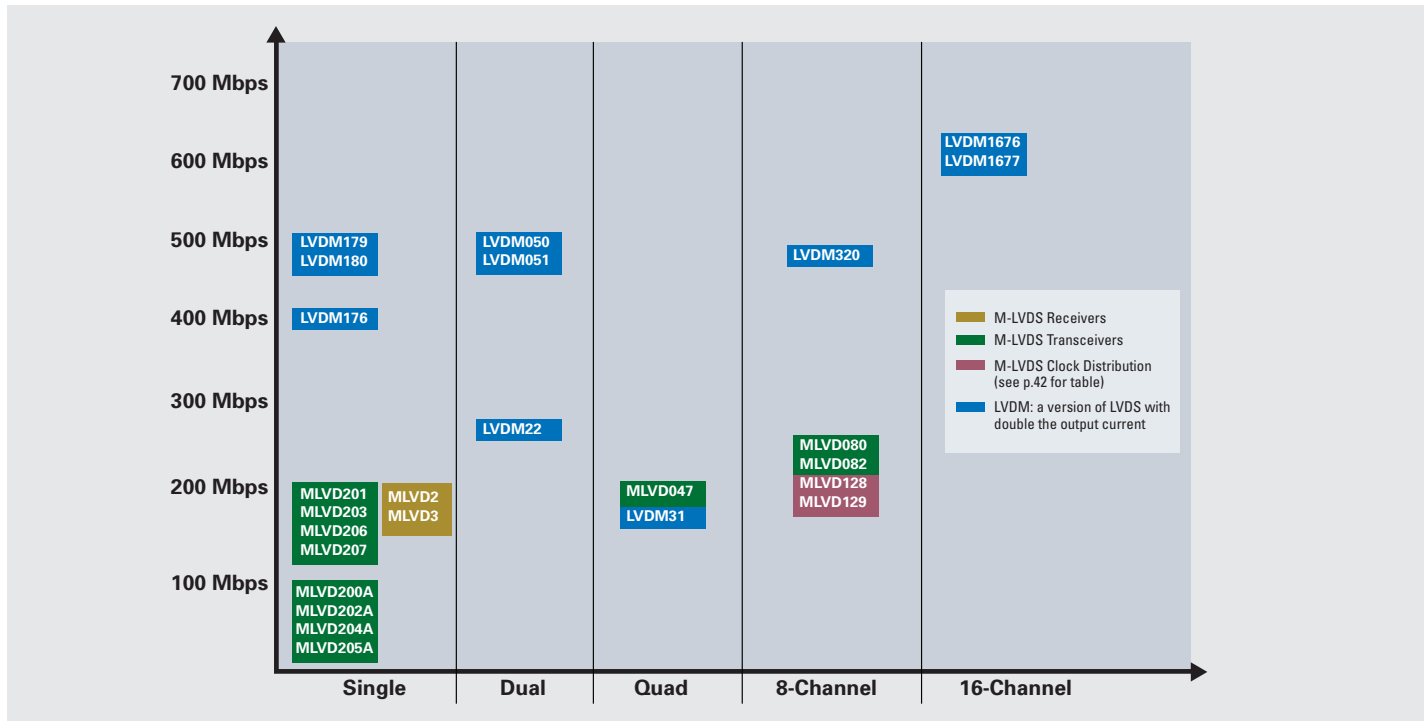



M-LVDS Selection Guide

Device ¹	No. of Tx	No. of Rx	Rx Type	Half/Full Duplex	Input Signal	Output Signal	Signaling Rate (Mbps)	Part-to-Part Skew Max (ps)	Tx tpd Typ (ns)	Rx tpd Typ (ns)	I _{cc} Max (mA)	ESD HBM (kV)	Pin/Package(s)	TIA/EIA-899 Standard Compliance	Price*
SN65MLVD2	—	1	1	—	M-LVDS	LVTTTL	200	—	—	—	—	—	—	✓	Web
SN65MLVD3	—	1	2	—	M-LVDS	LVTTTL	200	—	—	—	—	—	—	✓	Web
SN65MLVD200A	1	1	1	Half	LVTTTL, M-LVDS	LVTTTL, M-LVDS	100	1000	2.5	3.6	24	8	8SOIC	✓	1.55
SN65MLVD201	1	1	1	Half	LVTTTL, M-LVDS	LVTTTL, M-LVDS	200	1000	1.5	4	24	8	8SOIC	✓	1.85
SN65MLVD202A	1	1	1	Full	LVTTTL, M-LVDS	LVTTTL, M-LVDS	100	1000	2.5	3.6	24	8	14SOIC	✓	1.55
SN65MLVD203	1	1	1	Full	LVTTTL, M-LVDS	LVTTTL, M-LVDS	200	1000	1.5	4	24	8	14SOIC	✓	1.85
SN65MLVD204A	1	1	2	Half	LVTTTL, M-LVDS	LVTTTL, M-LVDS	100	1000	2.5	3.6	24	8	8SOIC	✓	1.55
SN65MLVD205A	1	1	2	Full	LVTTTL, M-LVDS	LVTTTL, M-LVDS	100	1000	2.5	3.6	24	8	14SOIC	✓	1.55
SN65MLVD206	1	1	2	Half	LVTTTL, M-LVDS	LVTTTL, M-LVDS	200	1000	1.5	4	24	8	8SOIC	✓	1.85
SN65MLVD207	1	1	2	Full	LVTTTL, M-LVDS	LVTTTL, M-LVDS	200	1000	1.5	4	24	8	14SOIC	✓	1.85
SN65MLVD047	4	0	—	Half	LVTTTL	M-LVDS	200	1000	1.5	—	60	12	16SOIC, 16TSSOP	✓	1.45
SN65MLVD128	8	1	—	—	LVTTTL	M-LVDS	200	800	1.5	1.5	140	8	48TSSOP	✓	3.80
SN65MLVD129	8	2	—	—	LVTTTL	M-LVDS	200	800	1.5	1.5	140	8	48TSSOP	✓	3.80
SN65MLVD080	8	8	1	Half	LVTTTL, LVDS	LVTTTL, M-LVDS	250	1000	2.4	6	180	8	64TSSOP	✓	4.75
SN65MLVD082	8	8	2	Half	LVTTTL, LVDS	LVTTTL, M-LVDS	250	1000	2.4	6	180	8	64TSSOP	✓	4.75
SN65LVDM179	1	1	—	Full	LVTTTL, LVDM	LVTTTL, LVDM	500	1000	1.7	3.7	15	12	8SOIC, 8VSSOP	—	1.70
SN65LVDM050 ²	2	2	—	Full	LVTTTL, LVDM	LVTTTL, LVDM	500	1000	1.7	3.7	27	12	16SOIC, 16TSSOP	—	2.20
SN65LVDM22	2	2	—	—	LVDM	LVDM	250	—	4	4	27	12	16SOIC, 16TSSOP	—	2.50
SN65LVDM31	4	0	—	—	LVC MOS	LVDM	150	1000	2.3	—	40	12	16SOIC	—	1.55
SN65LVDM1676	16	16	—	Half	LVTTTL, LVDM	LVTTTL, LVDM	630	1000	2.5	3	175	15	64TSSOP	—	7.75

¹Supply voltage for all devices listed above is 3.3 V and temperature range is -40 to 85°C.

²Automotive version available, temperature range of -40 to 125°C

*Suggested resale price in U.S. dollars in quantities of 1,000.

New products are listed in **bold red**.

Preview products are listed in **bold blue**.

Resources

For a complete list of resources (evaluation modules, data sheets and application notes), visit interface.ti.com

Literature Number	Description
Application Notes	
SLLA106	TIA/EIA-485 and M-LVDS, Power and Speed Comparison
SLLA088A	Transmission at 200 Mbps in VME Card Cage Using LVDM (Rev. A)
SLLA108	Introduction to M-LVDS (TIA/EIA-899)
SLLA121	Interoperability of M-LVDS and BusLVDS
SLLA119	Wired-Logic Signaling with M-LVDS
SLLA127	M-LVDS Signaling Rate Versus Distance
SLLA067A	Comparing Bus Solutions

Part Number	Description	Price*
Evaluation Modules (EVMs)		
MLVD20xEVM	M-LVDS Evaluation Module	99.00
SN65LVDM31-32BEVM	SN65LVDM31-32BEVM Evaluation Module	49.00

Note: IBIS models are available at interface.ti.com

*Suggested resale price in U.S. dollars.



Design Considerations

Reliability — Best-in-class, high voltage and functional reliability with > 25 years.

Magnetic Immunity — Immunity from external magnetic fields to prevent data corruption is a critical consideration for industrial applications. 1E6 times higher magnetic immunity than inductive couplers.

Signaling rate — TI offers digital isolators with the highest signaling rates of up to 150 Mbps.

Jitter — To ensure signal integrity, jitter reduction is a priority. ISO72xx products offer the lowest jitter with 1-ns jitter at 150-Mbps PRBS NRZ data input.

Key Features

- 4000- V_{peak} isolation
 - UL 1577, IEC 60747-5-2 (VDE 0884, Rev. 2)
 - IEC 61010-1 and CSA approved
 - 50-kV/ μs transient immunity
- Signaling rate 0 Mbps to 150 Mbps
 - Low propagation delay
 - Low pulse skew (pulse-width distortion)
- Low-power sleep mode
- High-electromagnetic immunity
- Low-input current requirement of 10 μA
- Fail-safe output

Technical Information

The ISO72xx is a family of digital isolators using the industry's first application of digital capacitive isolation technology. Digital buffers capacitively couple data signals through a silicone-dioxide (SiO_2) insulation barrier which provides galvanic isolation of up to 4000 V. The device receives digital inputs and provides clean digital outputs while preventing noise currents and/or excessive voltages from entering the local ground.

Recently introduced alternative isolation techniques that use magnetic coupling may still share the deficiencies of the older opto-coupler solutions such as a restricted operating temperature along with new concerns such as the absence of a fail-safe output, an inability to operate with DC-only signals and concerns associated with susceptibility to external magnetic fields and operating life under high-voltage conditions. TI isolation solutions are designed to eliminate such problems.

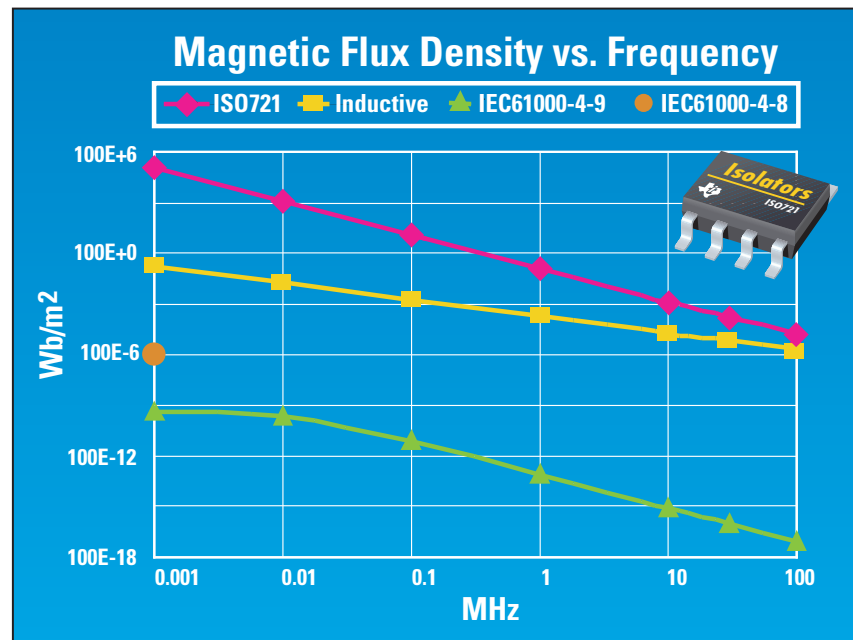

Digital Isolators Selection Guide

Device	Description	Isolation Rating (UL)	Low-Power Sleep Mode	Data Rate (Max)	Transient Immunity (Min)	Supply Voltage	Price*
ISO721	Single channel (TTL)	2500 V_{RMS}	No	100 Mbps	25 kV/ μs	3.3 V, 5 V	1.65
ISO721M	Single channel (CMOS)	2500 V_{RMS}	Yes	150 Mbps	25 kV/ μs	3.3 V, 5 V	1.65
ISO722	Single channel OUT EN (TTL)	2500 V_{RMS}	Yes	100 Mbps	25 kV/ μs	3.3 V, 5 V	1.75
ISO722M	Single channel OUT EN (CMOS)	2500 V_{RMS}	Yes	150 Mbps	25 kV/ μs	3.3 V, 5 V	1.75
ISO150	Dual channel bi-directional	1500 V_{RMS}	No	80 Mbps	1.6 kV/ μs	5 V	8.10
ISO7220A	Dual channel uni-directional (TTL)	2500 V_{RMS}	No	1 Mbps	25 kV/ μs	3.3 V, 5 V	1.10
ISO7220C	Dual channel uni-directional (TTL)	2500 V_{RMS}	No	25 Mbps	25 kV/ μs	3.3 V, 5 V	2.00
ISO7220M	Dual channel uni-directional (CMOS)	2500 V_{RMS}	No	150 Mbps	25 kV/ μs	3.3 V, 5 V	2.50
ISO7221A	Dual channel bi-directional (TTL)	2500 V_{RMS}	No	1 Mbps	25 kV/ μs	3.3 V, 5 V	1.10
ISO7221C	Dual channel bi-directional (TTL)	2500 V_{RMS}	No	25 Mbps	25 kV/ μs	3.3 V, 5 V	2.00
ISO7221M	Dual channel bi-directional (CMOS)	2500 V_{RMS}	No	150 Mbps	25 kV/ μs	3.3 V, 5 V	2.50

*Suggested resale price in U.S. dollars in quantities of 1,000.

New products are listed in **bold red**.
Preview products are listed in **bold blue**.



Design Considerations

Interoperability — In general, RS-485 is a superset of RS-422. Compliance with the TIA/EIA standard will ensure reliable data communication in a variety of networks, including Modbus, INTERBUS, PROFIBUS, BACnet and a variety of proprietary protocols.

Robustness — RS-485 is a robust interface standard for use in industrial environments. It features a wide common mode range of -7 V to 12 V. Parts from TI are available with ESD protection up to 30 kV.

Reliability — Integrated fail-safe circuitry protects the bus from interpreting noise as valid data when short-circuit, open-circuit or idle line fault conditions occur.

Speed and Distance — Low noise coupling of differential signaling with twisted-pair cabling and wide common-mode voltage

range allows data exchange at signaling rates of up to 50 Mbps or to distances of several kilometers at lower rates.

Line Loading — RS-422 is capable of supporting one driver and up to 10 receivers on the bus line. Standard RS-485 is capable of supporting up to 32 unit loads or nodes on the bus line. However, there are reduced unit load devices available that can support up to 256 devices.

Termination — A multipoint bus architecture requires termination at both ends of the bus line. The termination resistors must be within

20 percent of the characteristic impedance of the cable and can vary from 90 Ω to 120 Ω.

Technical Information

- The main difference between RS-422 and RS-485 is the multidrop and multipoint bus architecture—that is, one driver to many receivers and many drivers to many receivers, respectively.
- Typical signaling rates and distances for these standards are up to 10 Mbps or up to 1.2 km. TI offers devices capable of reaching signaling rates of up to 50 Mbps.

Resources For a complete list of resources (evaluation modules, data sheets and application notes), visit interface.ti.com

Literature Number	Description
Application Notes	
SLLA036B	Interface Circuits for TIA/EIA-485 (RS-485)
SLLA070C	422 and 485 Standards Overview and System Configurations
SLLA112	RS-485 for E-Meter Applications
SLLA177	PROFIBUS Electrical-Layer Solutions
SLLA169	Use Receiver Equalization to Extend RS-485 Data Communications
SLLA143	RS-485 for Digital Motor Control Applications

Note: IBIS models are available at interface.ti.com

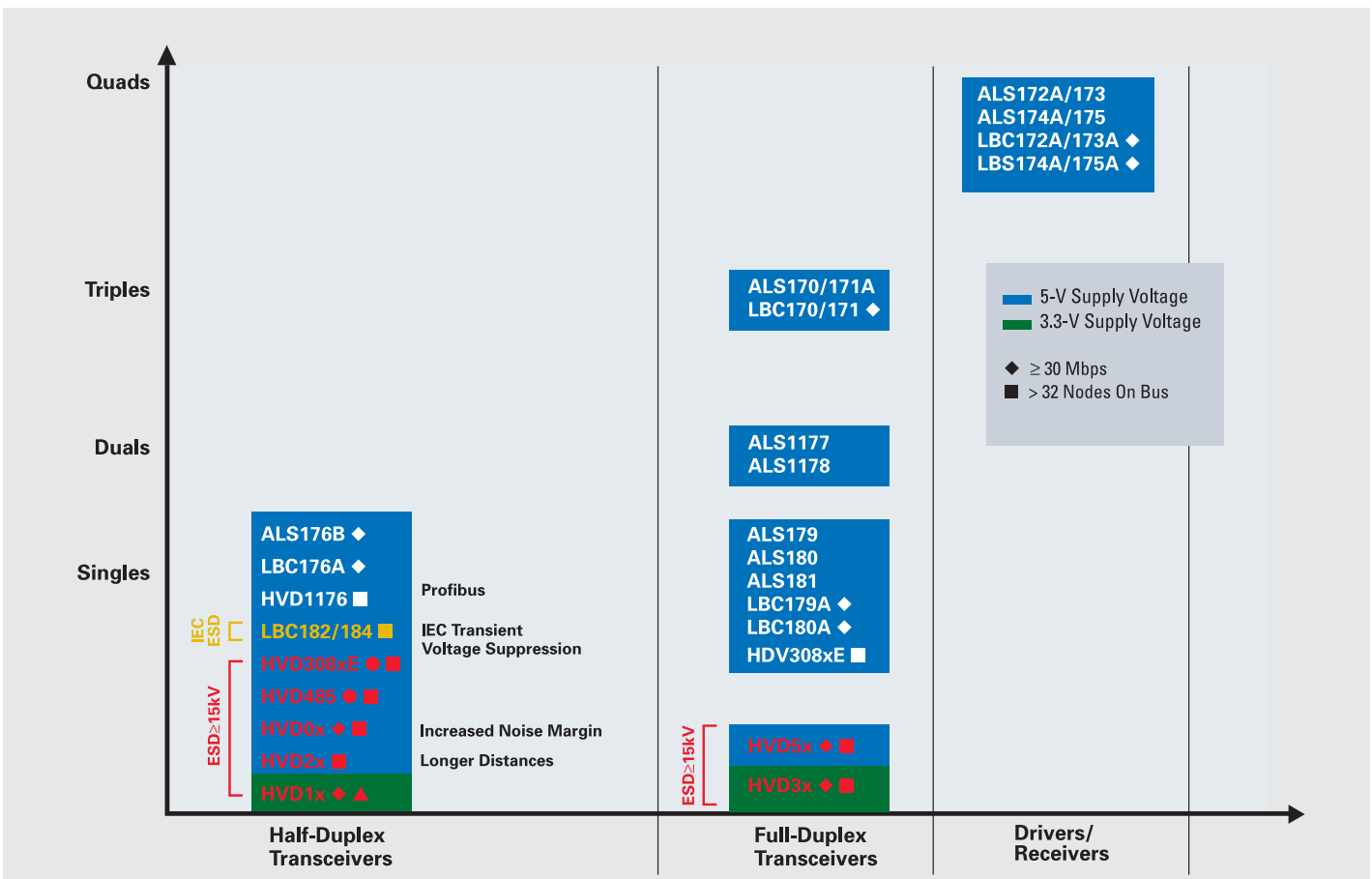



RS-485/422 Selection Guide

No. of Dr/Rx	Supply (V)	Enables	Device ¹	Features	Signaling Rate (Mbps)	ESD (kV)	Receiver Fail-Safe	Nodes	Package(s)	Price*		
1/1	Half-Duplex	3.3	DE, RE	HVD12	3.3V Supply – Low-Speed Slew-Rate Control	1	15	Short, Open, Idle	256	8-PDIP, 8-SOIC	1.75	
			DE, RE	HVD11	3.3V Supply – Low-Speed Slew-Rate Control	10	15	Short, Open, Idle	256	8-PDIP, 8-SOIC	1.80	
		3 to 5	DE, RE	HVD10	3.3V Supply – High-Speed Signaling	25	15	Short, Open, Idle	64	8-PDIP, 8-SOIC	1.85	
			DE, RE	HVD08	Wide Supply Range: 3 to 5.5V	10	15	Short, Open, Idle	256	8-PDIP, 8-SOIC	1.90	
		DE, RE	HVD3082E	Low Power Mode, Optimized for Low-Speed	0.2	15	Short, Open, Idle	256	8-PDIP, 8-SOIC, 8-MSOP	0.90		
		DE, RE	HVD3085E	Low Power Mode, Optimized for Mid-Speed	1	15	Short, Open, Idle	256	8-PDIP, 8-SOIC, 8-MSOP	0.90		
		DE, RE	HVD3088E	Low Power Mode, Optimized for High-Speed	10	15	Short, Open, Idle	256	8-PDIP, 8-SOIC, 8-MSOP	1.00		
		DE, RE	HVD485E	Half Duplex Transceiver	10	15	Open	64	8-PDIP, 8-SOIC, 8-MSOP	0.70		
		DE, RE	HVD1176	PROFIBUS Transceiver, EN 50170	40	10	Short, Open, Idle	160	8-SOIC	1.55		
		DE, RE	HVD22	–20V to 25V Common Mode Operation	0.5	16	Short, Open, Idle	256	8-PDIP, 8-SOIC	1.65		
		DE, RE	HVD21	–20V to 25V Common Mode, 5Mbps	5	16	Short, Open, Idle	256	8-PDIP, 8-SOIC	1.65		
		DE, RE	HVD20	–20V to 25V Common Mode, 25Mbps	25	16	Short, Open, Idle	64	8-PDIP, 8-SOIC	1.65		
		5	DE, RE	HVD23	Receiver Equalization, 160 Meters at 25 Mbps	25	16	Short, Open, Idle	64	8-PDIP, 8-SOIC	1.80	
			DE, RE	HVD24	Receiver Equalization, 500 Meters at 3 Mbps	3	16	Short, Open, Idle	256	8-PDIP, 8-SOIC	1.80	
	DE, RE		HVD07	Strong Driver Outputs – Low Signal Rate	1	16	Short, Open, Idle	256	8-PDIP, 8-SOIC	1.50		
	DE, RE		HVD06	Strong Driver Outputs – Mid Signal Rate	10	16	Short, Open, Idle	256	8-PDIP, 8-SOIC	1.55		
	DE, RE		HVD05	Strong Driver Outputs – Fast Signal Rate	40	16	Short, Open, Idle	64	8-PDIP, 8-SOIC	1.60		
	DE, RE		LBC176	Low Power	10	2	Open	32	8-PDIP, 8-SOIC	0.90		
	DE, RE		LBC176A	Low Power, Fast Signaling, ESD Protection	30	12	Open	32	8-PDIP, 8-SOIC	1.20		
	DE, RE		LBC184	Transient Protection, IEC Air, Contact, Surge	0.25	30	Open	128	8-PDIP, 8-SOIC	1.30		
	DE, RE		LBC182	IEC ESD Protection, Air and Contact Tests	0.25	15	Open	128	8-PDIP, 8-SOIC	1.05		
	DE, RE		ALS176	Fast Signaling, Skew: 15ns	35	2	Open	32	8-SOIC	1.26		
	DE, RE		176B	Cost Effective	10	2	None	32	8-PDIP, 8-SOIC, 8-SOP	0.44		
	Full-Duplex		3.3	No	HVD30	3.3V Supply, no Enables, 25Mbps	25	15	Short, Open, Idle	64	8-SOIC	1.80
				No	HVD31	3.3V Supply, no Enables, 5Mbps	5	15	Short, Open, Idle	256	8-SOIC	1.80
				No	HVD32	3.3V Supply, no Enables, 1Mbps	1	15	Short, Open, Idle	256	8-SOIC	1.80
		No		HVD379	Balanced Receivers, Ideal for Interbus	25	15	None	256	8-SOIC	1.95	
		DE, RE		HVD33	3.3V Supply, with Enables, 25Mbps	25	15	Short, Open, Idle	64	14-SOIC	1.85	
DE, RE		HVD34		3.3V Supply, with Enables, 5Mbps	5	15	Short, Open, Idle	256	14-SOIC	1.85		
DE, RE		HVD35		3.3V Supply, with Enables, 1Mbps	1	15	Short, Open, Idle	256	14-SOIC	1.85		
No		HVD50		Strong Bus Outputs, no Enables, 25Mbps	25	15	Short, Open, Idle	64	8-SOIC	1.70		
No		HVD51		Strong Bus Outputs, no Enables, 5Mbps	5	15	Short, Open, Idle	256	8-SOIC	1.70		
No		HVD52		Strong Bus Outputs, no Enables, 1Mbps	1	15	Short, Open, Idle	256	8-SOIC	1.70		
No		HVD179		Balanced Receivers, Ideal for Interbus	25	15	None	256	8-SOIC	1.85		
No		LBC179		Low Power, without Enable	10	2	Open	32	8-PDIP, 8-SOIC	0.85		
No		LBC179A		High Signaling Rate, High ESD w/o Enables	30	10	Open	32	8-PDIP, 8-SOIC	1.10		
5		DE, RE		HVD53	Strong Bus Outputs, with Enables, 25Mbps	25	15	Short, Open, Idle	64	14-SOIC	1.60	
		DE, RE	HVD54	Strong Bus Outputs, with Enables, 5Mbps	5	15	Short, Open, Idle	256	14-SOIC	1.60		
		DE, RE	HVD55	Strong Bus Outputs, with Enables, 1Mbps	1	15	Short, Open, Idle	256	14-SOIC	1.60		
		DE, RE	LBC180	Low Power, with Enables	10	2	Open	32	14-PDIP, 14-SOIC, 16-QFN	1.05		
		DE, RE	ALS180	High Signaling Rate, with Enables	25	2	Open	32	14-SOIC	1.71		
		DE, RE	ALS1177	Dual full-duplex drivers/receivers	10	2	Open	32	16-PDIP, 16-SOIC	3.24		
		1DE, 2DE	ALS1178	Dual full-duplex drivers/receivers	10	2	Open	32	16-PDIP, 16-SOIC	3.24		
		3/3 Triple	Separate DIR	LBC170	FAST-20 SCSI, Skew: 3ns	30	12	Open	32	20-SOIC, 16-SSOP	4.10	
			DE, Triple RE	LBC171	FAST-20 SCSI, Skew: 3ns	30	12	Open	32	20-SOIC, 20-SSOP	4.10	
		4/0 Quad-Drivers	Complementary	LBC172	Low Power	10	2	—	32	16-PDIP, 20-SOIC	1.80	
			Complementary	LBC172A	High Signaling Rate, High ESD	30	13	—	32	16-PDIP, 16-SOIC, 20-SOIC	2.40	
			Pairwise	LBC174	Low Power	10	2	—	32	16-PDIP, 20-SOIC	1.90	
			Pairwise	LBC174A	High Signaling Rate, High ESD	30	13	—	32	16-PDIP, 16-SOIC, 20-SOIC	2.50	
		0/4 Quad-Receivers	Complementary	LBC173	Low Power	10	2	Open	32	16-PDIP, 16-SOIC	1.15	
Complementary			LBC173A	High Signaling Rate, High ESD, Low Power	50	6	Short, Open, Idle	32	16-PDIP, 16-SOIC	1.50		
Pairwise	LBC175		Low Power	10	2	Open	32	16-PDIP, 16-SOIC	1.10			
Pairwise	LBC175A		High Signaling Rate, High ESD, Low Power	50	6	Short, Open, Idle	32	16-PDIP, 16-SOIC	1.40			
Pairwise	175		Standard	10	2	None	32	16-PDIP, 16-SOIC, 16-SOP	2.70			

¹These devices use the temperature prefixes: SN55 = military (–55° C to 125° C); SN65 = industrial (–40° C to 85° C); SN75 = commercial (0° C to 70° C).

*Suggested resale price in U.S. dollars in quantities of 1,000.



RS232: IEC6100-4-2 (Level 4) ESD-Protected Devices

TI offers new RS-232 devices with system-level IEC61000-4-2 electrostatic discharge (ESD) protection. This protection makes the RS-232 interface immune to damage from ESD strikes that may occur while the system is up and running, such as when a connection to the RS-232 cable is made. These devices are drop-in replacements and are functionally identical to the existing industry-standard solutions, providing a seamless transition in the qualification process. These devices meet the requirements for low-power, high-speed applications such as portable/consumer, telecom and computing equipment.

TI offers these new devices in the NiPdAu Pb-Free finish, which eliminates tin whiskers that might compromise long-term system reliability. TI offers the space-saving QFN package on select devices in addition to its already extensive RS-232 portfolio.

Key Features

- No external ESD device needed with these system-level ESD ratings:
 - ± 15 -kV human-body model (HBM)
 - ± 8 -kV IEC61000-4-2, contact discharge
 - ± 15 -kV IEC61000-4-2, air-gap discharge
- Improved drop-in replacement of popular RS-232 devices
- Data rates meet or exceed today's high-speed-application requirements
- Flexible power-saving options enable longer battery life
- Wide portfolio permits selection of the right form, fit and functionality
- Industry-leading interface product space with assured source of supply
- NiPdAu Pb-Free solution provides whisker-free, reliable package options
- Space-saving QFN package options for portable applications

Applications

- The three-driver, five-receiver MAX3243E is most popular in applications like PCs, notebooks and servers.
- The MAX3238E/37E offer complementary five-driver, three-receiver solutions. These two devices are popular in PC peripheral applications like data cables, printers, modems, industrial control, etc.
- The MAX3227E/23E/22E/21E are popular in portable handheld applications due to their reduced bit count, package size and low power consumption.
- Higher-speed versions like the SNx5C3232E/23E/22E/21E meet today's higher throughput needs through the serial interface.
- The MAX232E and MAX213 provide a higher noise margin for more rugged environments such as industrial control.

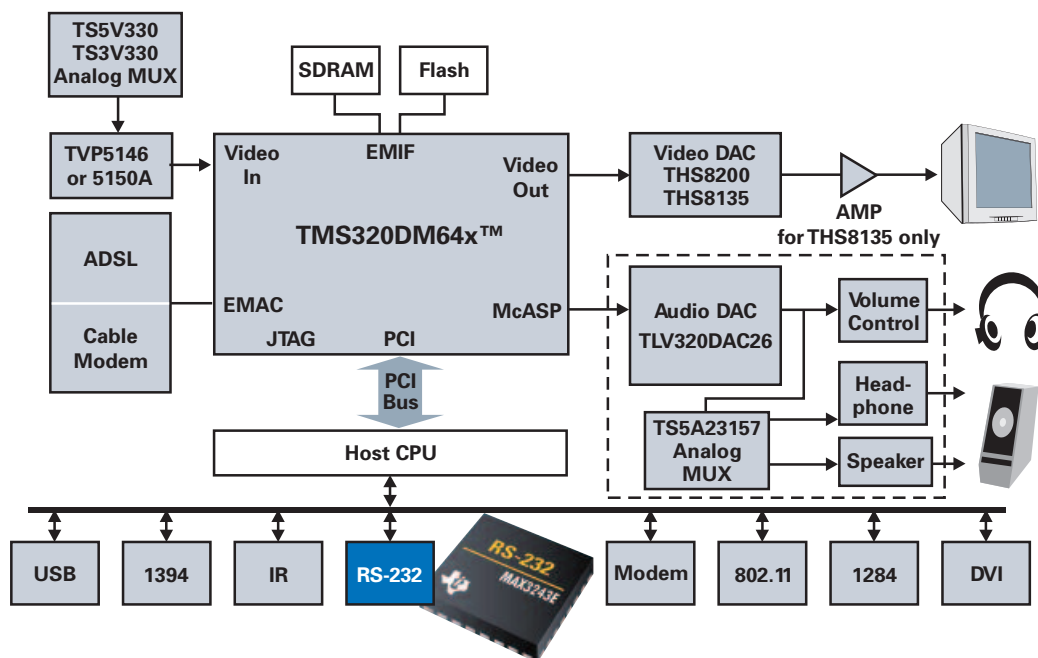

Personal video recorder application block diagram.



RS232 Selection Guide

Device	Data Rate (kbps)	Drivers	Receivers	ESD HBM (kV)	Supply Voltage(s) (V)	I _{CC} (max) (mA)	Pin/Package(s)	Price*
MAX3223E	500	2	2	IEC61000-4-2	3.3, 5	1	20SOIC, 20SSOP, 20TSSOP, 24QFN	0.84
MAX3222E	500	2	2	IEC61000-4-2	3.3, 5	1	20SOIC, 20SSOP, 20TSSOP, 24QFN	1.00
SN75C3222E	1000	2	2	IEC61000-4-2	3.3, 5	1	20SOIC, 20SSOP, 20TSSOP, 24QFN	2.50
SN65C3222E	1000	2	2	IEC61000-4-2	3.3, 5	1	20SOIC, 20SSOP, 20TSSOP, 24QFN	2.88
SN75C3223E	1000	2	2	IEC61000-4-2	3.3, 5	1	20SOIC, 20SSOP, 20TSSOP, 24QFN	2.11
SN65C3223E	1000	2	2	IEC61000-4-2	3.3, 5	1	20SOIC, 20SSOP, 20TSSOP, 24QFN	2.50
MAX3238E	400	5	3	IEC61000-4-2	3.3, 5	2	28SSOP, 28TSSOP, 32RHB	0.87
MAX3221E	250	1	1	IEC61000-4-2	3.3, 5	1	16SSOP, 16TSSOP	0.88
SN65C3221E	1000	1	1	IEC61000-4-2	3.3, 5	1	16SSOP, 16TSSOP	3.10
SN75C3221E	1000	1	1	IEC61000-4-2	3.3, 5	1	16SSOP, 16TSSOP	2.50
MAX3237E	1000	5	3	IEC61000-4-2	3.3, 5	2	28SSOP, 28TSSOP, 32RHB	0.87
ADM2209E	960	10	6	IEC61000-4-2	Dual 3.3V, 12V	5	38TSSOP	TBD
MAX232E	120	2	2	IEC61000-4-2	5	10	38TSSOP, 16PDIP, 16SOIC, 16SSOP	0.39
MAX202E	120	2	2	IEC61000-4-2	5	15	16SOIC, 16TSSOP	TBD
MAX207E	120	5	3	IEC61000-4-2	5	20	24SOIC, 24SSOP	TBD
MAX208E	120	4	4	IEC61000-4-2	5	20	24PDIP, 24SOIC, 24SSOP	TBD
MAX3386E	250	3	2	IEC61000-4-2	VL 1.65V to V _{CC} , V _{CC} 3V to 5.5V	1	20SOIC, 20TSSOP	1.92
SN65C3232E	1000	2	2	IEC61000-4-2	3.3, 5	1	16SOIC, 16SSOP, 16TSSOP	3.92
SN75C3232E	1000	2	2	IEC61000-4-2	3.3, 5	1	16SOIC, 16SSOP, 16TSSOP	3.22
MAX211E	120	4	5	IEC61000-4-2	5	20	20SOIC, 20SSOP, 28SOIC, 28SSOP	TBD
MAX3227E	1000	1	1	IEC61000-4-2	3.3, 5	1	16SSOP	1.20
MAX3232E	250	2	2	IEC61000-4-2	3.3, 5	1	16SOIC, 16SSOP, 16TSSOP	0.68
MAX3243E	500	3	5	IEC61000-4-2	3.3, 5	1	28SOIC, 28SSOP, 28TSSOP, 32QFN	0.63
MAX3318E	460	2	2	IEC61000-4-2	2.25, 3	1	20SSOP, 20TSSOP	1.10
MAX213	120	4	5	15KV HBM	5	1	28SOIC, 28SSOP	1.08
MAX202	120	2	2	15KV HBM	5	15	16SOIC, 16TSSOP	0.51
MAX207	120	5	3	15KV HBM	5	20	24SOIC, 24SSOP	0.63
MAX208	120	4	4	15KV HBM	5	20	24PDIP, 24SOIC, 24SSOP	0.96
MAX211	120	4	5	15KV HBM	5	20	28SOIC, 28SSOP	0.63
MAX222	120	2	2	15KV HBM	5	10	18PDIP, 18SOIC	0.74
MAX3221	250	1	1	15KV HBM	3.3, 5	1	16SSOP, 16TSSOP	0.88
MAX3223	250	2	2	15KV HBM	3.3, 5	1	20SOIC, 20SSOP, 20TSSOP	1.12
MAX3232	250	2	2	15KV HBM	3.3, 5	1	16SOIC, 16SSOP, 16TSSOP	0.96
MAX3238	250	5	3	15KV HBM	3.3, 5	2	28SSOP, 28TSSOP	1.20
MAX3243	250	3	5	15KV HBM	3.3, 5	1	28SOIC, 28SSOP, 28TSSOP	0.88
MAX3318	460	2	2	15KV HBM	2.25, 3	2	20SSOP, 20TSSOP	1.58
SN65C23243	250	6	10	15KV HBM	3.3, 5	0.02	48SSOP, 48TSSOP	4.32
SN65C3221	1000	1	1	15KV HBM	3.3 or 5	1	16SOIC, 16SSOP, 16TSSOP	2.38
SN65C3223	1000	2	2	15KV HBM	3.3 or 5	1	20SOIC, 20SSOP, 20TSSOP	2.50
SN65C3232	1000	2	2	15KV HBM	3.3 or 5	1	16SOIC, 16SSOP, 16TSSOP	3.02
SN65C3238	1000	5	3	15KV HBM	3.3 or 5	2	28SOIC, 28SSOP, 28TSSOP	3.24
SN65C3243	1000	3	5	15KV HBM	3.3 or 5	1	28SOIC, 28SSOP, 28TSSOP	3.46
SN75C23243	250	6	10	15KV HBM	3.3, 5	0.02	48SSOP, 48TSSOP	3.42
SN75C3221	1000	1	1	15KV HBM	3.3 or 5	1	16SOIC, 16SSOP, 16TSSOP	1.94
SN75C3223	1000	2	2	15KV HBM	3.5 or 5	1	20SOIC, 20SSOP, 20TSSOP	2.38
SN75C3232	1000	2	2	15KV HBM	3.3 or 5	1	16SOIC, 16SSOP, 16TSSOP	2.79
SN75C3238	1000	5	3	15KV HBM	3.3 or 5	2	28SOIC, 28SSOP, 28TSSOP	2.81
SN75C3243	1000	3	5	15KV HBM	3.3 or 5	1	28SOIC, 28SSOP, 28TSSOP	1.51
SN75LP1185	256	3	5	15KV HBM	5, ±12	1	20PDIP, 20SOIC, 20SSOP	1.78
SN75LP196	256	5	3	15KV HBM	5, ±12	1	20PDIP, 20SOIC, 20SSOP, 20TSSOP	1.78
SN75LPE185	256	3	5	15KV HBM	5, ±12	1	24PDIP, 24SOIC, 24SSOP, 24TSSOP	1.89
SN75185	120	3	5	10KV HBM	±12, 5	30	20PDIP, 20SOIC, 20SSOP, 20TSSOP	0.45
SN75196	120	5	3	10KV HBM	±12, 5	20	20PDIP, 20SOIC	0.68
SN75LV4737A	128	3	5	4KV HBM	3 or 5	20.7	28SSOP	2.61
MAX232	120	2	2	2KV HBM	5	10	16PDIP, 16SO, 16SOIC	0.48
SN75150	120	2		2KV HBM	-12	22	8PDIP, 8SOIC	0.72
SN75155	120	1	1	2KV HBM	-12	14	8PDIP, 8SOIC	0.72
SN75188	120	4		2KV HBM	-9	25	14PDIP, 14SO, 14SOIC	0.22

*Suggested resale price in U.S. dollars in quantities of 1,000.

New products are listed in **bold red**.
Preview products are listed in **bold blue**.



RS-232 Selection Guide (Continued)

Device	Data Rate (kbps)	Drivers	Receivers	ESD HBM (kV)	Supply Voltage(s) (V)	I _{cc} (max) (mA)	Pin/Package	Price*
SN75C1406	120	3	3	2KV HBM	± 12, 5	0.45	16PDIP, 16SO, 16SOIC	0.86
SN75C185	120	3	5	2KV HBM	± 12, 5	0.75	20PDIP, 20SOIC	1.08
SN75C188	120	4	—	2KV HBM	-12	0.16	14PDIP, 14SO, 14SOIC, 14SSOP	0.31
TL145406	120	3	3	2KV HBM	± 12, 5	20	16PDIP, 16SOIC	0.94
GD65232	120	3	5	—	±9, 5	38	20PDIP, 20SOIC, 20SSOP, 20TSSOP	0.29
GD75232	120	3	5	—	±9, 5	30	20PDIP, 20SOIC, 20SSOP, 20TSSOP	0.27
GD75323	120	5	3	—	± 12, 5	32	20SOIC	0.41
LT1030	120	4	—	—	-5	1	14PDIP, 14SOIC	1.44
MAX3222	120	2	2	—	3.3, 5	1	20SOIC, 20SSOP, 20TSSOP	1.36
MC1488	120	4	—	—	-9	25	14PDIP	0.20
MC1489	120	—	4	—	5	26	14PDIP	0.25
MC1489A	120	—	4	—	5	26	14PDIP	0.29
SN65C1154	120	4	4	—	—	—	20PDIP	3.42
SN65C1406	120	3	3	—	± 12, 5	—	16SOIC	1.80
SN65C3222	120	2	2	—	3.3 or 5	1	20SOIC, 20SSOP, 20TSSOP	3.24
SN75154	120	4	4	—	5 or 12	35	16PDIP, 16SO, 16SOIC	0.72
SN751701	120	1	1	—	± 5, 9, 12	11.9	8SO	1.30
SN75186	120	1	1	—	± 12, 5	—	24SOIC	1.80
SN75189	120	—	4	—	5	26	14PDIP, 14SO, 14SOIC	0.22
SN75189A	120	—	4	—	5	26	14PDIP, 14SO, 14SOIC	0.22
SN752232	120	6	10	—	5	+/-50	48SSOP, 48TSSOP	0.90
SN75C1154	120	4	4	—	± 12, 5	—	20PDIP, 20SO, 20SOIC	0.76
SN75C189	120	—	4	—	5	0.7	14PDIP, 14SO, 14SOIC	0.31
SN75C189A	120	—	4	—	5	0.7	14PDIP, 14SO, 14SOIC, 14SSOP	0.31
SN75C198	120	4	—	—	-12	0.32	14PDIP, 14SOIC	2.25
SN75C3222	120	2	2	—	3.3 or 5	1	20SOIC, 20SSOP, 20TSSOP	2.81
SN75LBC187	120	3	5	—	5	30	28SSOP	3.60
SN75LBC241	120	4	5	—	5	8	28SOIC	2.16
UA9636A	120	2	—	—	-12	36	8PDIP, 8SOIC	0.36
UC5170C	120	—	—	—	—	—	28PLCC	3.15
UC5180C	120	—	8	—	4.75 to 5.25	35	28PLCC	3.00
UC5181C	120	—	8	—	4.75 to 5.25	35	28PLCC	3.15

*Suggested resale price in U.S. dollars in quantities of 1,000.

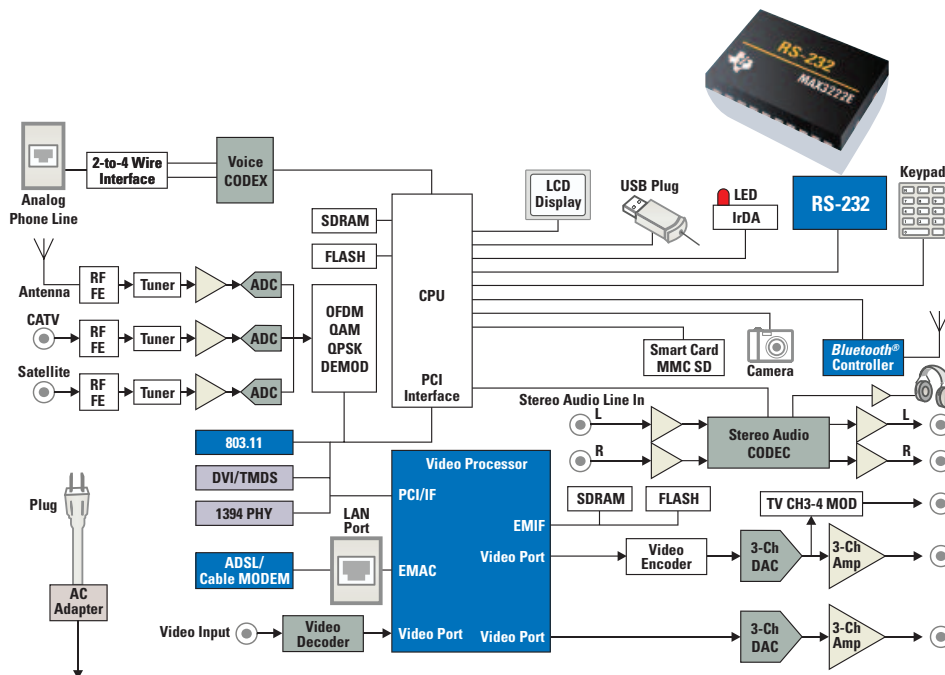

PDA interface application block diagram.



Design Considerations

The UART is a key component of an asynchronous serial communications system. For example, all internal modems have their own UARTs. In this application, parallel data within the computer is converted by the UART to serial data before being transferred to the modem. In addition to PC/peripheral communication, UARTs can be used for chip-to-chip communications.

As data transfer speeds have increased to support applications such as telecommunication base stations, cell phones, PCs, fax servers and rack modems, the transmission rate of the UART has become critical to

preventing system bottlenecks. When a fast external modem is used, designers should be sure the computer's UART can handle the modem's maximum transmission rate. For example, the TL16C550D UART contains a 16-byte buffer, enabling it to support higher sustained transmission rates than the older 8250 UART. To reduce software buffering and data overruns, TI has added its patented hardware autoflow control to all new designs and most existing UARTs. Most UARTs allow the divisor to be programmed from 1 to 65,535 and sometimes with an added predivisor factor of 1, 4, 16 or 64.

To accommodate the requirements of diverse applications, TI offers a wide portfolio of parallel-to-serial and serial-to-parallel UARTs in highly integrated, space-saving configurations that allow designers to increase system performance while decreasing space requirements.

As one of the world's leading high-volume semiconductor manufacturers, TI offers designers and OEMs the satisfaction of knowing they are backed by a supplier with the resources to meet their needs. These include a dedicated marketing and technical support team to assist with any issues.

Key Features

- Single-, dual- and quad-channel devices
- 16- and 64-byte FIFOs available
- 5-, 3.3-, 2.5- and 1.8-V supply
- Clock rates up to 24/20/16-MHz for 1.5/1.25/1.0-Mbps data transfer rates
- Hardware and software autoflow control
- Programmable sleep mode and low-power mode
- Industrial temperature characterization

UART Family of Products

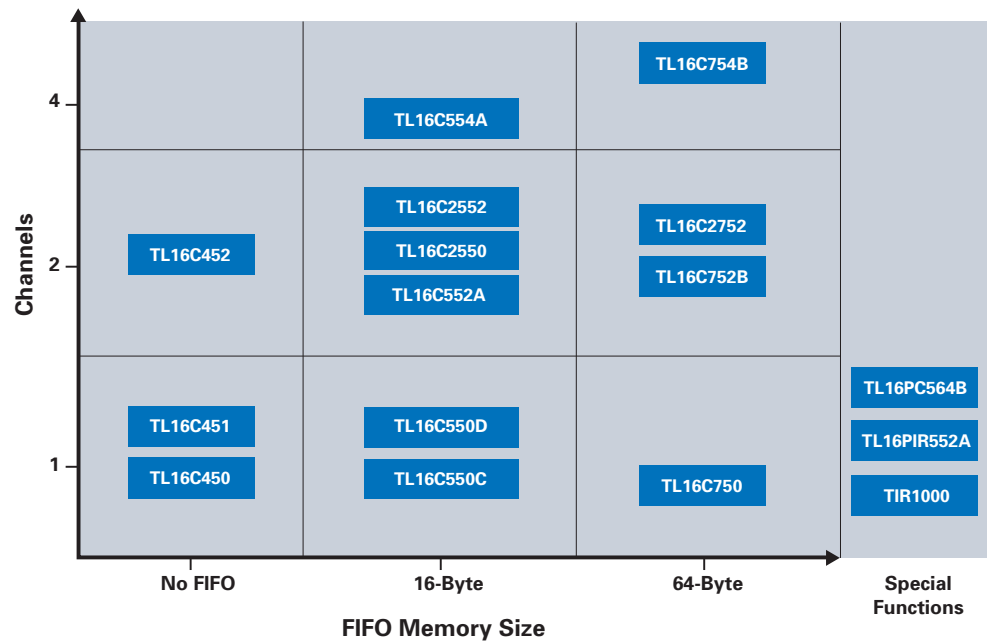



UART Selection Guide

Device	Channel(s)	FIFOs	Voltage (V)	Characterized Temp. (°C)	Package(s)	Description	Price*
Universal Asynchronous Receiver/Transmitters (UARTs)							
TL16C2550	2	16-Byte	1.8/2.5/3.3/5	-40 to 85	32 QFN, 44 PLCC, 48 TQFP	Dual UART with Programmable Auto-RTS and Auto-CTS	2.80
TL16C2552	2	16-Byte	1.8/2.5/3.3/5	-40 to 85	32 QFN, 44 PLCC	Dual UART with Programmable Auto-RTS and Auto-CTS	3.00
TL16C2752	2	64-Byte	1.8/2.5/3.3/5	—	44 PLCC	Dual UART with Customizable Trigger Levels	Call
TL16C450	1	None	5	0 to 70	40 DIP, 44 PLCC	Single UART	1.50
TL16C451	1	None	5	0 to 70	68 PLCC	Single UART with Parallel Port	2.50
TL16C452	2	None	5	0 to 70	68 PLCC	Dual UART with Parallel Port	2.55
TL16C550C	1	16-Byte	3.3/5	-40 to 85	40 DIP, 44 PLCC, 48 LQFP, 48 TQFP	Single UART with Hardware Autoflow Control	1.75
TL16C550D	1	16-Byte	2.5/3.3/5	-40 to 85	32 QFN, 48 LQFP, 48 TQFP	Single UART with Hardware Autoflow Control	1.75
TL16C552A	2	16-Byte	5	-40 to 85	68 PLCC, 80 TQFP	Dual UART with Parallel Port	3.85
TL16C554A	4	16-Byte	5	-40 to 85	68 PLCC, 80 LQFP	Quad UART with Hardware Autoflow Control	6.00
TL16C750	1	16/64-Byte	5	-40 to 85	44 PLCC, 64 LQFP	Single UART with Hardware Autoflow Control, Low-Power Modes	3.70
TL16C752B	2	64-Byte	3.3	-40 to 85	48 LQFP, 48 TQFP	Dual UART with Hardware Autoflow Control, Low-Power Modes	3.10
TL16C754B	4	64-Byte	3.3/5	-40 to 85	68 PLCC, 80 LQFP	Dual UART with Hardware Autoflow Control, Low-Power Modes	8.35
TL16PC564B/BLV	1	16/64-Byte	3.3/5	0 to 70	100 BGA, 100 LQFP	Single UART with PCMCIA Interface	5.90/6.10
TL16PIR552	2	16-Byte	5	0 to 70	80 QFP	Dual UART with Selectable IR & 1284 Modes	6.10

*Suggested resale price in U.S. dollars in quantities of 1,000.

TL16C550D Asynchronous Communications Element

Get samples, datasheets, EVMs and reports at: www.ti.com/sc/device/TL16C550D

Asynchronous Communications Element with Autoflow Control

The TL16C550D is a performance-enhanced version of TI's industry-standard TL16C550C single-channel UART with 16-byte FIFO. The TL16C550D can support voltages of down to 2.5 V and data transfer rates of up to 1.5 Mbps. Combining these features with an ultra-small 32-pin QFN package, the TL16C550D is ideal for a variety of portable applications.

Key Features

- Expanded voltage and package options ideal for small form factors
- Lower voltage and higher frequency than TL16C550C
- Pin-for-pin replacement for TL16C550C
- Programmable auto-RTS and auto-CTS (autoflow)

- Up to 24/20/16-MHz clock rates for up to 1.5/1.25/1-Mbps operation
- Programmable baud-rate generator allows division to generate internal 16x clock
- Independent clock input receiver
- Fully programmable serial interface characteristics
- Available packages: DIP, PLCC, TQFP and QFN

Applications

- PDA's
- MP3 players
- Gaming systems
- Modems
- Serial ports
- Telecom

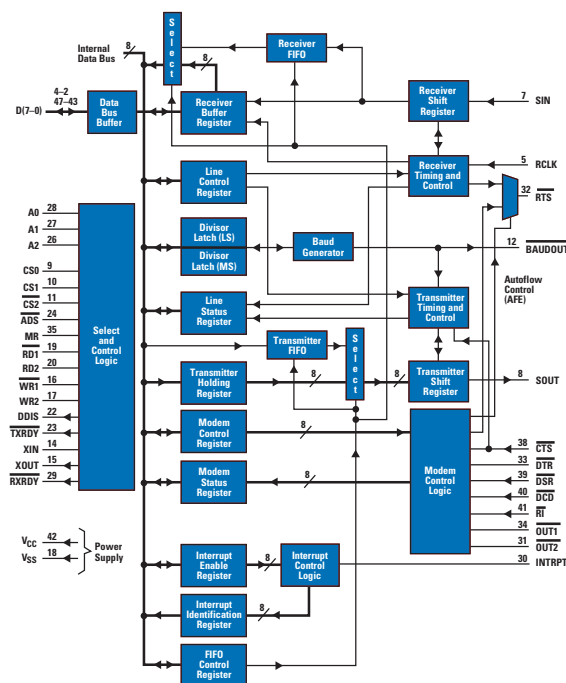

Functional block diagram.



Design Considerations

Bus Protection — Features such as short-circuit protection, thermal shutdown protection, glitch-free power-up and power-down protection, high-ESD protection, wide common-mode range that provides for common-mode noise rejection, and current-limiting circuitry to protect the transceivers and system from damage during a fault condition have been incorporated into these devices.

Electromagnetic Compatibility — An important requirement for products intended for networking applications is that they behave in a way that does not interfere with the operation of other nearby components or systems. TI offers specially designed and tested transceivers for EM compatibility without malfunction or degradation of performance in rugged EM environments. Compatibility in this definition means both immunity to external EM fields, and the limited strength of generated EM fields.

Supply Voltage — In addition to 5-V transceivers, TI offers 3.3-V transceivers that accomplish the same tasks with less than half the power and save on the cost of an additional voltage regulator in 3.3-V powered applications.

Technical Information

- ISO11898 specifies the physical-layer implementation of CAN.
- This specification describes a twisted wire pair bus with 120-Ω characteristic impedance (Z_0) and differential signaling rate of up to 1 Mbps on a 40-meter bus with multi-drop topology.

CAN Transceiver Selection Guide

Supply Voltage	Device	Description	I_{CC} Max (mA)	ESD (kV)	Bus Fault Protection (V)	Operating Temp Range	Price*
5.0	SN65HVD251	Improved Drop-In Replacement for the PCA82C250 and PCA82C251	65	±14	±36	–40 to 125° C	0.90
	SN65HVD1050	Improved Drop-In Replacement for the TJA1050 with Better ESD	70	±8	–27 to 40	–40 to 125° C	0.55
3.3	SN65HVD230	3.3-V CAN Bus Transceiver, Standby Mode	67	±16	–4 to 16	–40 to 85° C	1.35
	SN65HVD231	3.3-V CAN Bus Transceiver, Sleep Mode	67	±16	–4 to 16	–40 to 85° C	1.35
	SN65HVD232	3.3-V CAN Bus Transceiver, Cost Effective	67	±16	–4 to 16	–40 to 85° C	1.30
	SN65HVD233	3.3-V CAN Bus Transceiver, Standby Mode, Diagnostic Loop-back	56	±16	±36	–40 to 125° C	1.50
	SN65HVD234	3.3-V CAN Bus Transceiver, Standby Mode, Sleep Mode	56	±16	±36	–40 to 125° C	1.45
	SN65HVD235	3.3-V CAN Bus Transceiver, Standby Mode, Autobaud Loop-back	56	±16	±36	–40 to 125° C	1.50

All devices have a signaling rate of 1 Mbps.

*Suggested resale price in U.S. dollars in quantities of 1,000.

New products are listed in bold red.

Selection Guide

Device							
DSPs with CAN Controllers (3.3-V Supply Voltage)							
TMS320LF2403A	TMS320F2802-60	TMS320LC2403A	TMS320F2806	TMS320LF2406A	TMS320F2808	TMS320LC2406A	TMS320F2809
TMS320LF2407A	TMS320F2810	TMS320LF2407A	TMS320C2810	TMS320F2801	TMS320F2811	TMS320F2801-100	TMS320R2811
TMS320F2801-60	TMS320C2811	TMS320F28016	TMS320F2812	TMS320C2802	TMS320C2812	TMS320F2802-100	TMS320R2812
ARM7 Microprocessors with CAN Controllers (3.3-V Supply Voltage)							
TMS470R1A64	TMS470R1A384	TMS470R1A128	TMS470R1B512	TMS470R1A256	TMS470R1B768	TMS470R1A288	TMS470R1B1M

Standard Compliant Protocols

CAN is a serial communications bus for robust real-time control applications that is rapidly gaining the attention of industrial process, test, measurement and control engineers worldwide. It has excellent error detection and confinement capabilities, and has the flexibility to operate either as a primary backbone data communications network, as a secondary local embedded system, or as both. The engineering community is just now exploring the limits of what this bus can do when coupled with newly developed intelligent sensing technologies.

Besides CAN's high reliability, another of the main advantages of CAN when compared to alternative networks, is the availability of higher layer protocols (HLPs). There are many CAN-related system development packages prepared for these HLPs — hardware interface cards and easy-to-use software packages that provide system designers with a wide range of design and diagnostic tools. These components provide for the rapid development of complex control applications without building each node of a system network from scratch.

The HLP relieves a developer from the burden of dealing with CAN-specific details such as

bit-timing and implementation functions. It provides standardized communication objects for real-time data with Process Data Objects (PDOs) and Service Data Objects (SDOs), and provides special functions such as a time stamp, a sync message, and emergency shut-down procedures as well as network management, boot-up commands, and error management.

Among the most popular HLPs are CANopen, CANkingdom and DeviceNet with applications ranging from medical equipment to process control and assembly line coordination.



FlatLink™ 3G – Display SerDes for Mobile Phones

FlatLink 3G uses low EMI subLVDS to carry 24-bit color RGB data from applications processors, such as OMAP™ from TI, to the LCD Driver. It caters to screen resolutions from QVGA to XGA.

FPC cabling typically interconnects the Serializer-Transmitter with the display. Compared to parallel signaling, FlatLink 3G outputs significantly reducing the EMI of the interconnect by over 20 dB. The electromagnetic emission of the device itself is very low and meets the SAE J1752/3 'M'-specification.

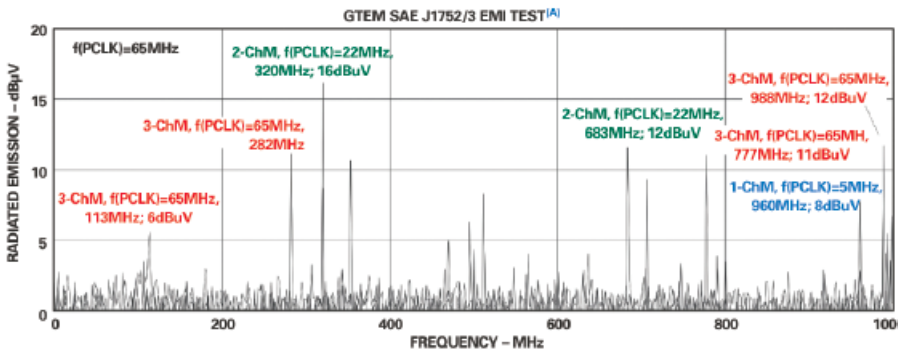
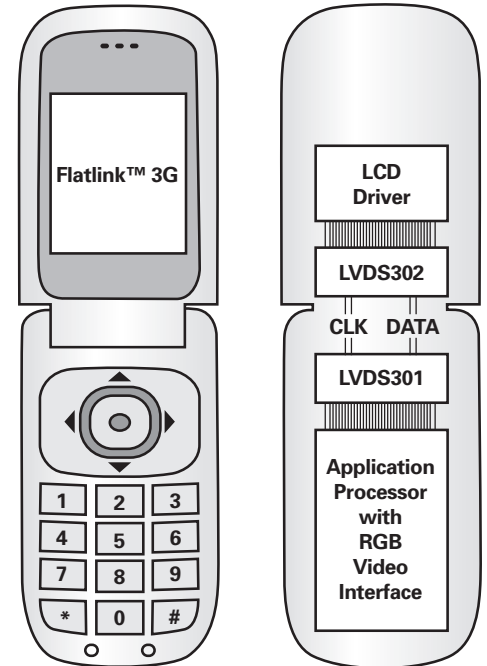

Resolution (W x H)		
QVGA	240	320
	640	200
CIF+	352	416
	352	440
HVGA	320	480
	800	250
	640	320
VGA	480	640
	1024	320
WVGA	480	800
SVGA	800	600
XGA	1024	768

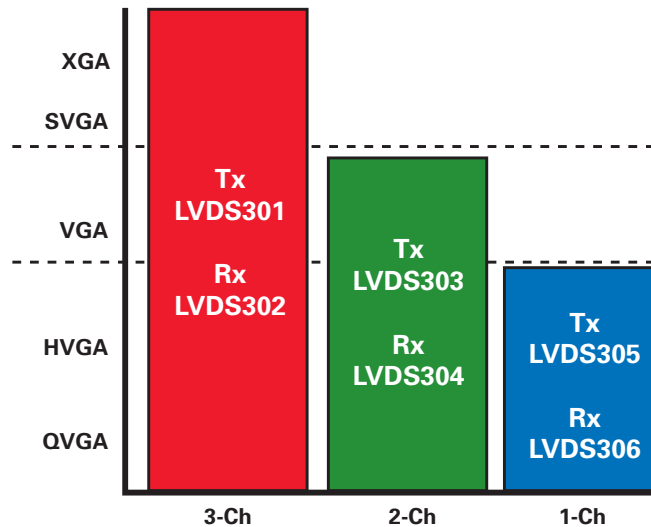

FlatLink™ 3G Selection Guide

Device	Description	Number of Parallel Outputs	Number of Parallel Inputs	Data Throughput (MB/s)	PLL Frequency (MHz)	Serial Data Receiver Channels	Serial Data Transmitter Channels	Price*
SN65LVDS301	QVGA-XGA Serializer Transmitter	—	27	1755	4-65	—	3	2.10
SN65LVDS302	QVGA-XGA Deserializer Receiver	27	—	1755	4-65	3	—	2.10
SN65LVDS303	QVGA-VGA Serializer Transmitter	—	27	810	4-30	—	2	Web
SN65LVDS304	QVGA-VGA Deserializer Receiver	27	—	810	4-30	2	—	Web
SN65LVDS305	QVGA-HVGA Serializer Transmitter	—	27	405	4-15	—	1	Web
SN65LVDS306	QVGA-HVGA Deserializer Receiver	27	—	405	4-15	1	—	Web

*Suggested resale price in U.S. dollars in quantities of 1,000.

New products are listed in bold red. Preview products are listed in bold blue.



The serial gigabit transceiver family of devices from TI provides low power dissipation while enabling multigigabit transmission over copper backplanes, cable and optical links. The transceivers can be used in a variety of applications, including Gigabit Ethernet, 10-Gigabit Ethernet modules, synchronous optical network (SONET) OC-48 and OC-192 based equipment, wireless infrastructure backplanes and general-purpose backplane applications.

SerDes Portfolio				
General Purpose	EPON	Gigabit Ethernet/FC	10 Gigabit Ethernet	LVDS
TLK3101 TLK2711 TLK2701 TLK2501 TLK1501 TLK4015 TLK2521 TLK1521 TLK4120 TLK4250	TLK1211	TLK1201AI TNETE2201 TLK2208B TLK2226 TLK2201BI TLK2201AJR	TLK3114SC TLK3104SA TLK3104SC TLK3118 TLK10021	SN65LVDS93/94 SN65LVDS95/96 SN65LV1023A/1224B SN75LVDS82/83 SN75LVDS84A/86 SN75LVDT1422

SerDes Solutions—Frontplane/Backplane

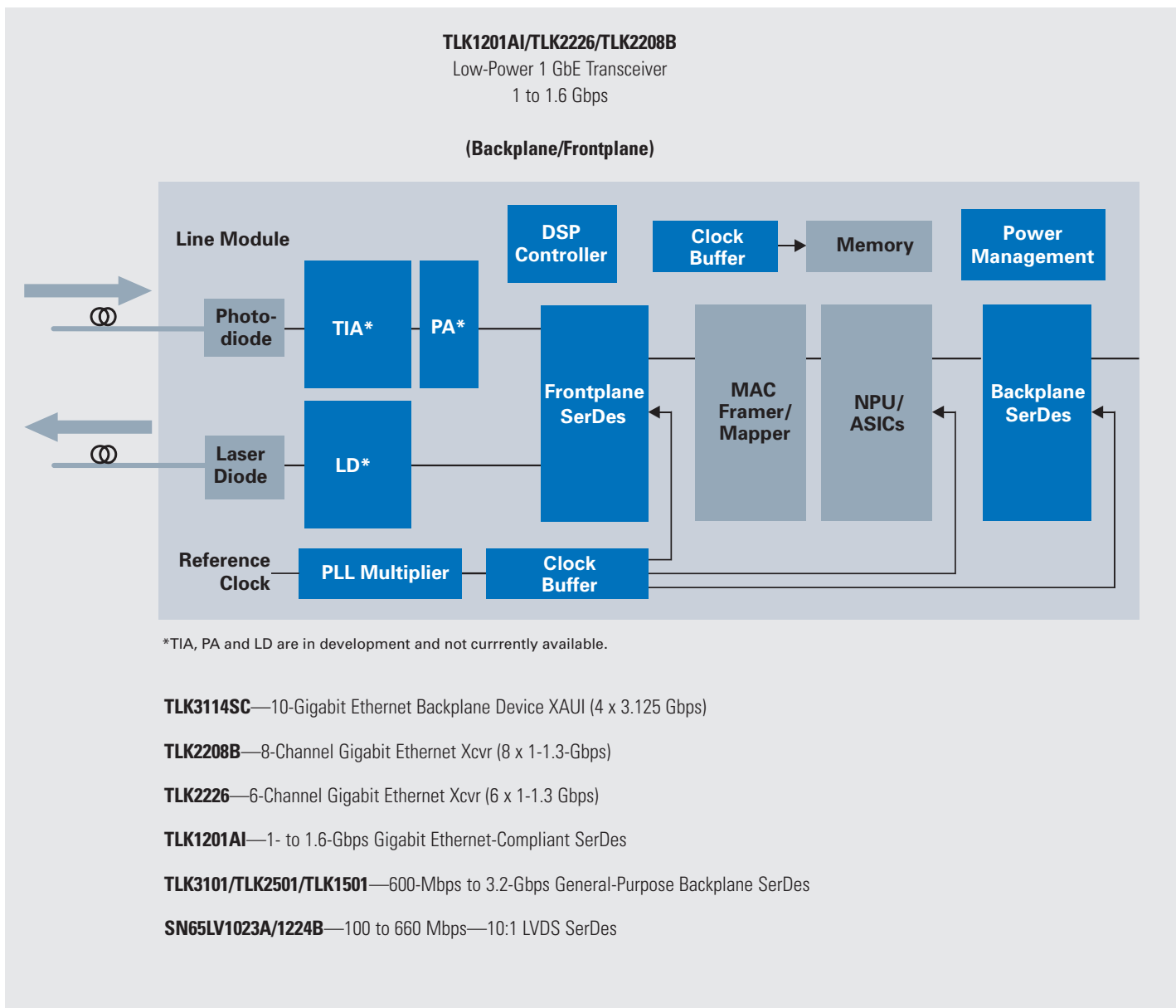



SerDes (Serial Gigabit Transceivers) Selection Guide

Device	Function	Data Rate	Serial I/F ¹	Parallel I/F	Power	Special Features	Price*
General Purpose							
TLK1501	Single-Ch. 16:1 SerDes	0.6-1.5 Gbps	1 CML	16 LVTTTL	200 mW	Built-In Testability	8.40
TLK2501	Single-Ch. 16:1 SerDes	1.6-2.5 Gbps	1 CML	16 LVTTTL	300 mW	Built-In Testability	12.60
TLK2701	Single-Ch. 16:1 SerDes	1.6-2.5 Gbps	1 CML	16 LVTTTL	300 mW	Built-In Testability and K Character Control	12.60
TLK2711	Single-Ch. 16:1 SerDes	1.6-2.5 Gbps	1 VML	16 LVTTTL	350 mW	MicroStar Junior™ BGA Packaging	10.50
TLK3101	Single-Ch. 16:1 SerDes	2.5-3.125 Gbps	1 VML	16 LVTTTL	350 mW	Built-In Testability	16.85
TLK2521	Single-Ch. 18:1 SerDes	1.0-2.5 Gbps	1 VML	18 LVTTTL	<550 mW	Low Power and Built-In Equalization	12.60
TLK1521	Single-Ch. 18:1 SerDes	0.6-1.3 Gbps	1 VML	18 LVTTTL	<350 mW	Low Power and Built-In Equalization	10.50
TLK4120	Four-Ch. 18:1 SerDes	0.5-1.3 Gbps	4 VML	18 LVTTTL	<350 mW	Four-Channel Version of TLK1521	24.00
TLK4250	Four-Ch. 18:1 SerDes	1.0-2.5 Gbps	4 VML	18 LVTTTL	<550 mW	Four-Channel Version of TLK2521	32.00
TLK4015	Four-Ch. of 16:1 Xcvr	0.6-1.5 Gbps/Ch.	4X CML	16 LVTTTL/Ch.	1 W	Four-Channel Version of TLK1501	29.40
EPON							
TLK1211	Single-Ch. 10:1 Gigabit Ethernet	0.6-1.3 Gbps	1 LVPECL	10 LVTTTL	200 mW	Fast Relock for PON	Web
Gigabit Ethernet/FibreChannel							
TLK1201AI	Single-Ch. 10:1 Gigabit Ethernet Xcvr Gbps	0.6-1.3	1 LVPECL	10 LVTTTL	200 mW	Industrial Temperature	4.85
TLK2201BI	Single-Ch. 10:1 Gigabit Ethernet Xcvr	1.2-1.6 Gbps	1 LVPECL	10 LVTTTL	200 mW	JTAG; 5-Bit DDR Mode, Industrial Temperature Qualified	4.65
TLK2201AJR	Single-Ch. 10:1 Gigabit Ethernet Xcvr	1.0-1.6 Gbps	1 LVPECL	10 LVTTTL	200 mW	MicroStar Junior 5 mm x 5 mm LGA	4.25
TLK2208B	Eight-Ch. of 10:1 Gigabit Ethernet Xcvr	1.0-1.3 Gbps	8 VML	4/5-Bit/Ch. (Nibble DDR Mode), 8/10-Bit/Ch. (Multiplex Ch. Mode)	1 W	JTAG, MDIO Supported	31.50
TLK2226	Six-Ch. 16:1 Gigabit Ethernet Xcvr	1.0-1.3 Gbps	6 VML	4/5-Bit RTBI or RGMII	<1.5 W	MDIO Supported 100-FX mode support	19.65
10 Gigabit (XAUI) Ethernet							
TLK3104SA	Four-Ch. of 10/8:1 Xcvr	2.5-3.125 Gbps	4X 3.125 Gbps LVPECL (XAUI)	4X 10/8-Bit SSTL/HSTL	700 mW/Ch.	JTAG; Programmable Pre-Emphasis and XAUI I/F	69.30
TLK3104SC	Four-Ch. of 4:1 Xcvr	3.0-3.125 Gbps	4X LVPECL	20X622 LVDS Lines	700 mW/Ch.	JTAG, 8b/10b On/Off	126.00
TLK3114SC	Four-Ch. of 10/8:1 Xcvr	2.5-3.125 Gbps	4X 3.125 Gbps LVPECL (XAUI)	4X 10/8-Bit SSTL/HSTL (XGMII)	600 mW/Ch.	IEEE 802.3ae Backplane Transceiver Compliant	57.75
TLK3118	Four-Ch. 10/8:1 Xcvr w/ (XAUI) Full Redundancy	2.5-3.125 Gbps/Ch.	4X 3.125 LVPECL (XAUI)	8/10 HSTLx4 (XGMII)	<2 W	Full Redundancy for Four Channels (XAUI)	80.00
TLK10021	Four XAUI to XFI	10 Gbps	1 XFI	4 XAUI	800 mW	Built-In Testability	Web
LVDS Serdes							
SN65LVDS93/94	Four-Ch. 28:4 TX/RX Chipset	140-455 Mbps/Ch.	5 LVDS	28 LVTTTL	250 mW/Chip	Supports Up to 1.82 Gbps Throughput	3.45
SN65LVDS95/96	Three-Ch. 21:3 TX/RX Chipset	140-455 Mbps/Ch.	4 LVDS	28 LVTTTL	250 mW/Chip	Supports Up to 1.82 Gbps Throughput	3.45
SN65LV1023A/1224B	Single-Ch. 10:1 TX/RX Chipset	100-660 Mbps	1 LVDS	10 LVTTTL	<400 mW	Low Power Solution	4.60
SN75LVDT1422	14:1 Xcvr SerDes	140 Mbps-1.4 Gbps	1 LVDS	14-Bit LVTTTL	<300 mW	Supports Spread Spectrum Clocking	3.70
SN75LVDS82/83	Four-Ch. 28:4 TX/RX Chipset	0.651-1.428 Gbps	4 LVDS	28 LVTTTL	250 mW/Chip	Commercial Temp	2.25
SN75LVDS84A/86	Three-Ch. 21:3 TX/RX Chipset	0.42-1.428 Gbps	3 LVDS	21 LVTTTL	250 mW/Chip	Commercial Temp	2.10

¹CML = Current Mode Logic; VML = Voltage Mode Logic.

*Suggested resale price in U.S. dollars in quantities of 1,000.

New products are listed in **bold red**.
Preview products are listed in **bold blue**.



Design Considerations

The Digital Visual Interface (DVI) Specification, is an industry standard developed by the Digital Display Working Group (DDWG) for high-speed digital connection to digital displays. DVI uses Transition-minimized DC balanced (TMDS) data signaling. Single link supports up to 165Mpixels/s – UXGA FPDs, SXGA DCRTs, 720p and 1080i HDTVs.

High Bandwidth Digital Content Protection (HDCP)

- Content protection for video sent over DVI
- Implementation of HDCP requires a license from the Digital Content Protection Licensing, L.L.C. (www.digital-cp.com)

HDCP Elements

- Authentication is a process for verifying that a device is authorized (e.g. licensed) to handle protected content.
- Encryption prevents eavesdropping of protected content.
- Renewability enables revocation of compromised devices.

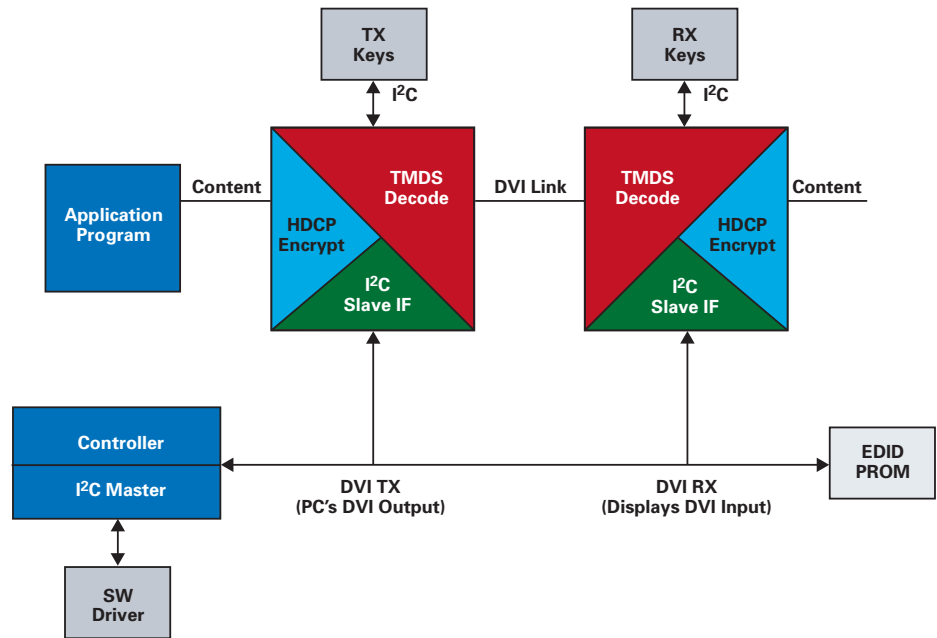

DVI-HDCP implementation.

PanelBus™ (DVI) Transmitters and Receivers

Device	Voltage (V)	Recvr./Trans. Channels	Parallel Outputs	Data Speed (Mbps)	I _{CC} (mA)	Package	Description	Price*
TFP401	3.3	3	48	495	400	100 HTQFP	DVI receiver, 165 MHz	4.00
TFP401A	3.3	3	48	495	400	100 HTQFP	DVI receiver, 165 MHz, HSYNC jitter immunity	4.00
TFP403	3.3	3	48	495	400	100 HTQFP	DVI receiver	5.45
TFP410	3.3	3	6	495	250	64 HTQFP	DVI transmitter, 165 MHz	3.00
TFP501	3.3	3	48	495	400	100 HTQFP	DVI receiver, 165 MHz plus HDCP	Call
TFP503	3.3	3	48	495	400	100 HTQFP	DVI receiver, 165 MHz plus HDCP and embedded HDCP keys	Call
TFP510	3.3	3	6	495	250	64 HTQFP	DVI transmitter, 165 MHz plus HDCP	Call
TFP513	3.3	3	6	495	250	64 HTQFP	DVI transmitter, 165 MHz plus HDCP and embedded HDCP keys	Call

*Suggested resale price in U.S. dollars in quantities of 1,000.



PanelBus™ HDCP Digital Receiver TFP501, TFP503

Get datasheets at: www.ti.com/TFP501 or www.ti.com/TFP503

The TFP501 and TFP503 are TI PanelBus flat panel display products, part of a comprehensive family of end-to-end DVI 1.0-compliant solutions. The TFP501/TFP503 support display resolutions up to UXGA, including the standard HDTV formats, in 24-bit true-color pixel format. The TFP501/TFP503 offer design flexibility to drive one or two pixels per clock, support TFT or DSTN panels and provide an option for time-staggered pixel outputs for reduced ground-bounce.

Key Features

- Supports UXGA resolution (output pixel rates up to 165 MHz)
- Digital visual interface (DVI) and high-bandwidth digital content protection (HDCP) specification compliant
- Encrypted external HDCP device key storage for exceptional security and ease of implementation
- True color, 24 bits/pixel, 48-bit dual-pixel output mode; 16.7/M colors at one or two pixels per clock
- 4x oversampling for reduced bit-error rates and better performance over longer cables
- Embedded HDCP keys (TFP503 only)
- Supports hot-plug detection
- Packaging: 100-pin TQFP PowerPAD™

Applications

- Desktop LCD monitors
- DLP® and LCD projectors
- Digital TVs

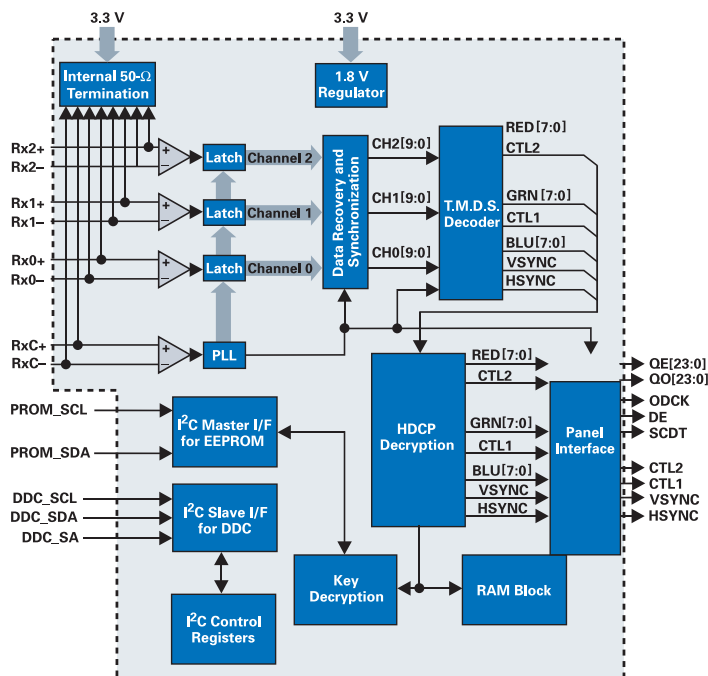

TFP501 block diagram.

TI PanelBus™ Digital Transmitters TFP510, TFP513

Get the datasheets and app reports at: www.ti.com/sc/device/TFP510 or www.ti.com/sc/device/TFP513

The TFP510 and TFP513 provide a universal interface allowing a glue-less connection to most commonly available graphics controllers. Some of the advantages of this universal interface include selectable bus widths, adjustable signal levels and differential and single-ended clocking. The DVI interface supports flat panel display resolutions up to UXGA at 165 MHz in 24-bit true color pixel format.

Key Features

- Digital visual interface (DVI) compliant
- Supports resolutions from VGA to UXGA (25-MHz to 165-MHz pixel rates)
- Universal graphics controller interface
 - 12-bit, dual-edge and 24-bit, single-edge input modes
 - Adjustable 1.1-V to 1.8-V and standard 3.3-V CMOS input signal levels
 - Fully differential and single-ended input clocking modes
 - Standard Intel® 12-bit digital video port compatible as on Intel 81x chipsets
- Programmable using I²C serial interface
- Monitor detection through hot-plug and receiver detection
- Embedded HDCP keys (TFP513 only)
- Packaging: 64-pin TQFP PowerPAD™

Applications

- Set-top boxes
- DVD recorders/players

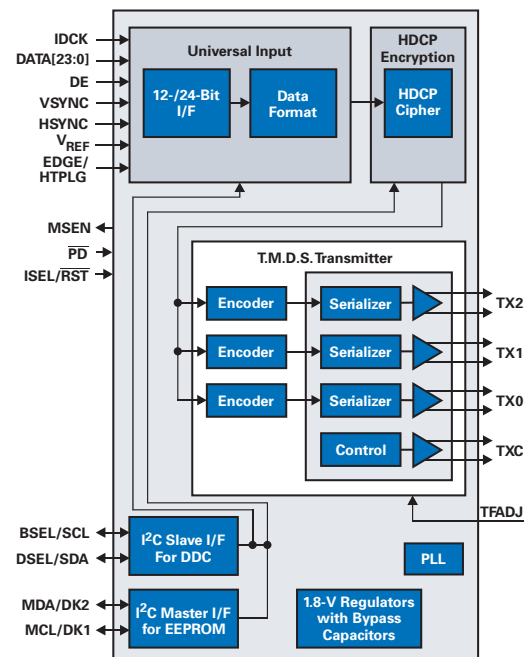

TFP510 block diagram.



TMDS (for HDMI and DVI)

Transition Minimized Differential Signaling (TMDS) is the electrical level standard used to transmit Digital Visual Interface (DVI) and High-Definition Multimedia Interface (HDMI) data.

Design Considerations

Intra-Pair Skew – The time difference between the true and complementary signals of a given differential pair should be kept as small as possible.

Residual Jitter – The difference in the amount of measured jitter between the test point and the signal source. It is the allowable maximum residual jitter is equivalent to the minimum jitter budget between transmitter and receiver.

ESD – External connectors being exposed to the outside world are especially susceptible to electrostatic discharge. A higher ESD rating provides improved protection.

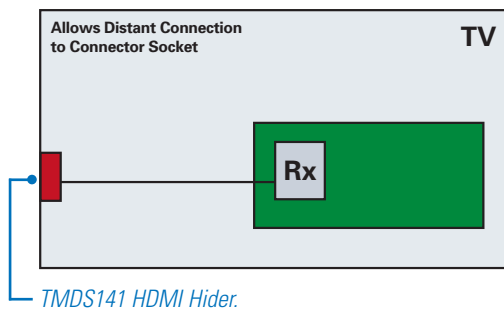
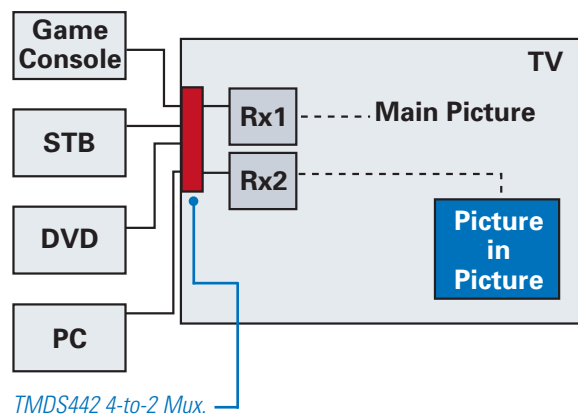
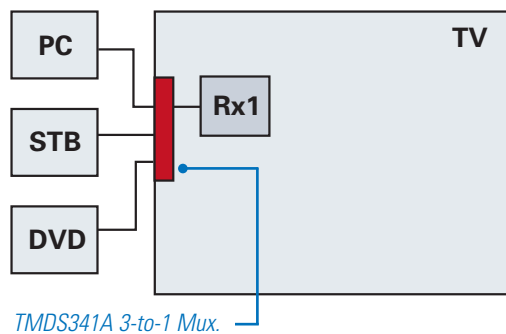

Device	Description	No. of Inputs	No. of Outputs	Intra-Pair Skew (max) (ps)	Inter-Pair Skew (max) (ps)	Clock P-P Jitter (max) (ps)	Data P-P Jitter (max) (ps)	ICC (max) (mA)	ESD HBM (kV)	Pin/Package	Price*
TMDS141	HDMI Hider	1	1	50	100	30	—	150	5	40QFN	Web
TMDS341A	3-to-1 DVI/HDMI Switch	3	1	50	100	30	50	230	5	80TQFP	3.50
TMDS442	4-to-2 DVI/HDMI Switch	4	2	50	100	30	—	550	5	128TQFP	Web
TS3DV416	4-to-1 Analog Switch for DVI/HDMI	4	1	—	—	—	—	—	2	48TSSOP, 48TVSOP	2.00
TS3DV520	4-to-1 Analog Switch for DVI/HDMI	5	1	—	—	—	—	—	2	56QFN	2.97

*Suggested resale price in U.S. dollars in quantities of 1,000.

New products are listed in **bold red**.
Preview products are listed in **bold blue**.



Universal Serial Bus (USB)

The USB standard defines a bus product that requires a host controller and enables plug-and-play connectivity. The most recently released final specification, USB 2.0, defines high speed and allows complete backward compatibility with USB 1.1.

USB products fall into three categories: hubs, host controllers and peripherals. USB 1.1 supported speeds of up to 12 Mbps and cables up to 5 meters long for these devices. USB 2.0 extends the connection speed to 480 Mbps to support next-generation peripherals of higher-performance PCs and applications. USB 2.0 officially defines three speeds: low (1.5 Mbps), full (12 Mbps) and high (480 Mbps). The lowest speed is ideal for human interface devices such as a mouse, game pad or keyboard; while full speed is well suited for “data dumps” to the PC via digital still cameras, PDA cradles and flash-card readers. Modems, printers, scanners and storage drives are just a few of the items that can take advantage of USB’s highest speed specification.

The USB On-The-Go (OTG) supplement to USB 2.0 specifies a new class of devices aimed at the portable market. USB OTG defines devices that can operate as standard USB peripherals when connected to a standard USB host controller.

However, these same devices can operate as reduced-function host controllers to support selected USB OTG peripheral devices. End-equipment manufacturers can specify what type of peripherals their devices will support when in OTG host mode. This new specification allows easy sharing of contact information between USB OTG PDAs and cell phones or printing of photographs directly from an OTG-enabled digital still camera without a PC.

Technical Information

Speed

- The USB 2.0 standard defines three speeds: low speed (LS) 1.5 Mbps, full speed (FS) 12 Mbps and high speed (HS) 480 Mbps. It requires full backward and forward compatibility for devices and

cables. All three modes offer both asynchronous and isochronous (real-time) data transmission over a simple and inexpensive 4-wire cable to meet requirements of peripherals including keyboards, mice, printers, speakers, scanners, external storage devices and digital still cameras.

Transfer Type

- USB 2.0 defines four types of transfers: bulk, control, interrupt and isochronous. Bulk transfer is intended for applications such as printers, scanners and mass storage, where latency isn’t critical but accuracy is. All devices must include control transfers for configuration. Interrupt transfer is for devices such as mice, keyboards and game pads that must receive the host’s or device’s attention periodically. Isochronous transfer offers guaranteed delivery time but no error-checking or automatic retransmission of data received with errors, making it the better choice for audio or video applications.

RS232/IrDA Serial-to-USB Converter

TUSB3410

Get samples, datasheets, EVMs and app reports at: www.ti.com/sc/device/TUSB3410

USB-to-Serial Bridge

The TUSB3410 provides an easy way to move a serial-based legacy device to a fast, flexible USB interface by bridging between a USB port and an enhanced UART serial port. The TUSB3410 contains all the necessary logic to communicate with the host computer using the USB bus.

Key Features

- USB full-speed-compliant: data rate of 12 Mbps
- 8052 microcontroller with 16 Kbytes of RAM that can be loaded from the host or from external onboard memory via an I²C bus
- Integrated, enhanced UART features including:
 - Programmable software/hardware flow control
 - Automatic RS-485 bus transceiver control, with and without echo
 - Software-selectable baud rate from 50 to 921.6 kbaud
 - Built-in, two-channel DMA controller for USB/UART bulk I/O
- Evaluation module to jump-start USB development or for use as a complete USB-to-RS-232 converter

Applications

- Handheld meters
- Health metrics/monitors
- Any legacy serial device that needs to be upgraded to USB

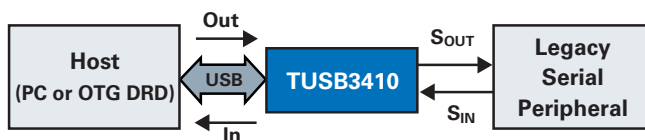

TUSB3410 data flow.



USB Family of Products

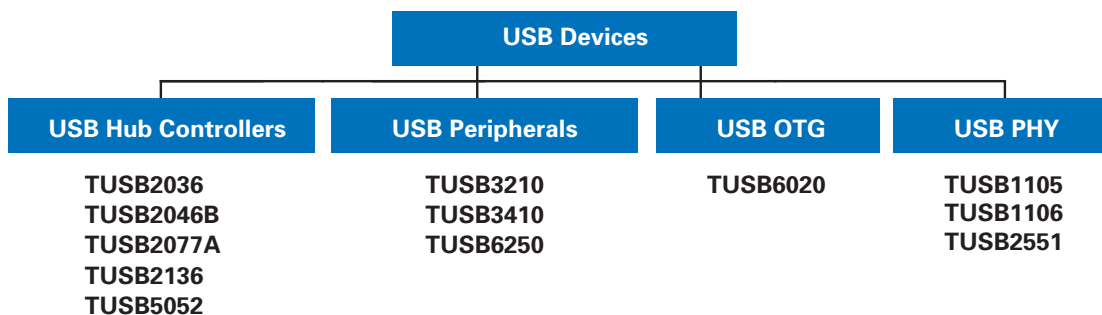

Selection Guide

Device	Speed	Ports	I ² C	Voltage (V)	Package	Description	Price*
USB Hub Controllers							
TUSB2036	Full (1.1)	2/3	No	3.3	32 LQFP	2/3-port hub for USB with optional serial EEPROM interface	1.15
TUSB2046B	Full (1.1)	4	No	3.3	32 LQFP	4-port hub for USB with optional serial EEPROM interface	1.20
TUSB2077A	Full (1.1)	7	No	3.3	48 LQFP	7-port USB hub with optional serial EEPROM interface	1.95
TUSB2136	Full (1.1)	1/2	Yes	3.3	64 LQFP	2-port hub with integrated general-purpose function controller	3.25
TUSB5052	Full (1.1)	1-5	Yes	3.3	100 LQFP	5-port hub with integrated bridge to two serial ports	5.10

Device	Speed	Voltage (V)	Remote Wakeup	Package	Description	Price*
USB Peripherals						
TUSB3210	Full	3.3	Yes	64 LQFP	USB full-speed general-purpose device controller	2.50
TUSB3410	Full	3.3	Yes	32 LQFP	USB-to-serial converter (RS-232, RS-485)	2.25
TUSB6250	Full, High	3.3	Yes	80 TQFP	USB 2.0 high-speed, low-power ATA/ATAPI bridge solution	2.80

Device	Speed	Voltage (V)	Package	Local Bus Interface	Description	Price*
USB On-The-Go (OTG)						
TUSB6020	High	1.5, 1.8, 3.3	80 QFP	VLINQ™	USB 2.0 High-Speed On-The-Go to Local Bus Interface Controller	Call

Device	Speed	Voltage (V)	Package	Single ended Input	Description	Price*
USB Transceivers						
TUSB1105	Full, Low	1.6, 3.6	16RTZ, 16RGT	Yes	USB Transceivers	Call
TUSB1106	Full, Low	1.6, 3.6	16RTZ, 16PW	No	USB Transceivers	Call
TUSB2551	Full, Low	1.6, 3.6	14PW, 16RGT	No	USB Transceivers	Call

*Suggested resale price in U.S. dollars in quantities of 1,000.

Preview products are listed in **bold blue**.

USB Port Protection—Transient voltage suppressor protects USB 1.1 devices from ESD and electrical noise transients.

Device	Description	Temp Range °C	Price*
USB Transceivers			
SN65220	Single suppressor	-40 to 85	0.33
SN65240	Dual suppressor	-40 to 85	0.41
SN75240	Dual suppressor	0 to 70	0.38

*Suggested resale price in U.S. dollars in quantities of 1,000.

Resources For a complete list of resources (evaluation modules, data sheets and application notes), visit interface.ti.com

Literature Number	Description
Application Notes	
SLLA122	Selection and Specification of Crystals for Texas Instruments USB 2.0 Devices
SLLA154	VIDs, PIDs and Firmware: Design Decisions When Using TI USB Device Controllers
SLLU043	TUSB3410 UART Evaluation Board
SLLA170B	USB/Serial Applications Using TUSB3410/5052 and the VCP Software
SLLAA276	MSP430 USB Connectivity Using TUSB3410



Design Considerations

USB High-Power Peripheral Switch With Dual Current Limit + LDO

TPS2140/41/50/51—The TPS2140/41/50/51 target high-power USB peripherals such as ADSL modems. The devices contain a power switch and an LDO. The dual-current-limiting switch allows the use of high-value capacitance to stabilize the voltage from the USB bus.

Dual Power Switch + LDO for USB Bus-Powered Peripherals and Hubs

TPS2148/49—TPS2148 is a complete power management solution for USB bus-powered peripherals such as zip drives, while TPS2149 is for USB bus-powered hubs, such as keyboards with integrated hubs. TPS2148/9 each combine a 3.3-V LDO and dual power switch in a single MSOP package. The TPS2148 switch configuration allows power and board capacitance segmentation to meet USB system current requirements. The TPS2149 switches manage two independent or four ganged USB ports.

4-Port USB Hub Power Controllers

TPS207x—The TPS207x family provides the complete power solution for 4-port self-powered, bus-powered or hybrid USB hubs by incorporating current-limited switches for four ports, a 3.3-V 100-mA LDO, a 5-V LDO controller for self power (TPS2070, TPS2071) and a DPO line control to signal an attach to the host.

Ease of Use—USB allows simplified installation and improved performance for peripheral devices by eliminating the need to repeatedly load new drivers and establish individual settings. USB combines a multitude of existing interfaces into a single easy-to-use connector, greatly reducing system complexity and offering manufacturers the ability to develop highly integrated products.

Power Distribution Switches

TPS204xB/5xB—The TPS204xB/5xB families of 80-mΩ current-limiting power switches meet all the USB power management requirements for controlling downstream ports, and include additional features to improve the design reliability. For example, when an over-current condition exists, the device intelligently shuts down only the port that sees the fault.

TPS202x/3x/6x—The TPS202x/3x/6x families of low on-resistance current-limiting power switches allow ganging of multiple ports to a single switch, as described in Application Note SLVA049. Though ganging can be cost-effective, all ports are affected by a fault.

USB Power Managers Family of Products

	Current Limit (min) (A)							
	0.22	0.3	0.66	0.7	1.1	1.5	1.65	2.2
USB Power Distribution Switches								
Quad	—	TPS2048A/58A	—	TPS2044B/54B	—	—	—	—
Triple	—	TPS2047B/57A	—	TPS2043B/53B	TPS2063/67	—	—	—
Dual	—	TPS2046B/56A	—	TPS2042B/52B	TPS2062/66	TPS2060/64	—	—
Single	TPS2020/30	TPS2045A/55A	TPS2021/31	TPS2041B/51B	TPS2022/32/61/65	—	TPS2023/33	TPS2024/34
4-Port USB Hub Power Controllers								
Device	5-V LDO Controller	Bus Power Mode Indicator	Pins	Package				
TPS2070	Yes	Active Low	32	HTSSOP				
TPS2071	Yes	Active High	32	HTSSOP				
TPS2074	No	Active Low	24	SSOP				
TPS2075	No	Active High	24	SSOP				

Dual Power Switch + LDO for USB Bus-Powered Peripherals and Hubs

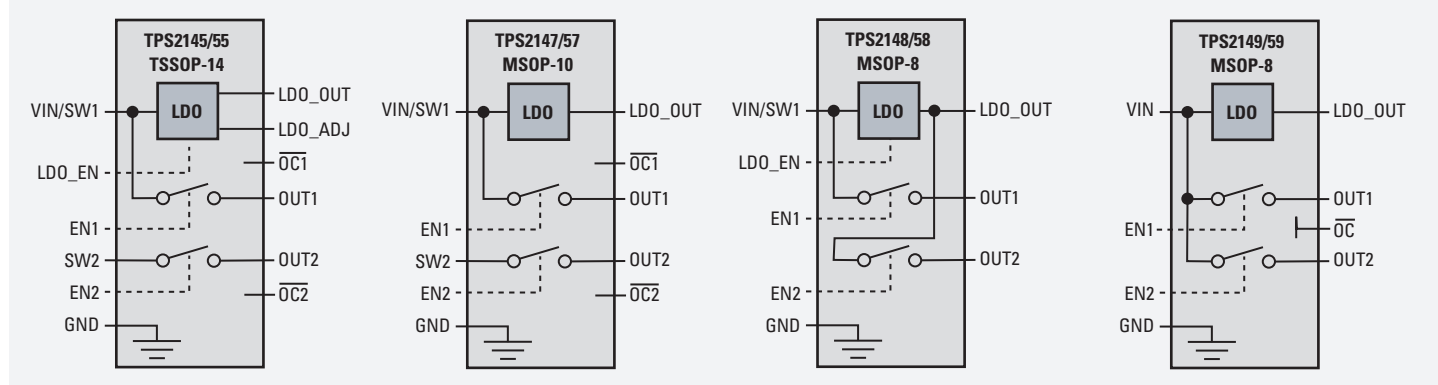



USB Power Managers Family of Products (Continued)

USB High-Power Peripheral Bus Switch + LDO		
Device	Switch Voltage	Description
TPS2140	3.3 V	3.3-V, 500-mA switch with active-low enable, 250-mA LDO
TPS2141	5.0 V	5.0-V, 500-mA switch with active-low enable, 250-mA LDO
TPS2150	3.3 V	3.3-V, 500-mA switch with active-high enable, 250-mA LDO
TPS2151	5.0 V	5.0-V, 500-mA switch with active-high enable, 250-mA LDO

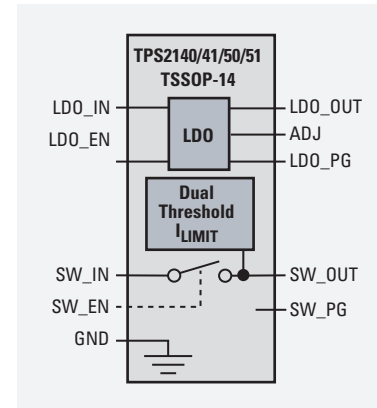

USB Power Managers Selection Guide

Device	Number of FETs	I _{OS} (min) (A)	r _{DS(on)} (mΩ)	V _{IN} Range (V)	Supply Current (μA)	OC Logic Output	OT Logic Output	Enable	Predecessor	Price*
USB Power Distribution Switches										
TPS2020/30	1	0.22	33	2.7 to 5.5	73	Yes	Yes	L/H	—	1.05
TPS2021/31	1	0.66	33	2.7 to 5.5	73	Yes	Yes	L/H	TPS2014	1.05
TPS2022/32	1	1.1	33	2.7 to 5.5	73	Yes	Yes	L/H	TPS2015	1.05
TPS2023/33	1	1.65	33	2.7 to 5.5	73	Yes	Yes	L/H	—	1.05
TPS2024/34	1	2.2	33	2.7 to 5.5	73	Yes	Yes	L/H	—	1.05
TPS2041B/51B	1	0.7	70	2.7 to 5.5	40	Yes	Yes	L/H	TPS2041/51/41A/51A	0.50
TPS2042B/52B	2	0.7	70	2.7 to 5.5	53	Each	Yes	L/H	TPS2042/52/42A/52A	0.70
TPS2043B/53B	3	0.7	70	2.7 to 5.5	65	Each	Yes	L/H	TPS2043/53/43A/53A	0.90
TPS2044B/54B	4	0.7	70	2.7 to 5.5	75	Each	Yes	L/H	TPS2044/54/44A/54A	1.00
TPS2045A/55A	1	0.3	80	2.7 to 5.5	80	Yes	Yes	L/H	TPS2045/55	0.60
TPS2046B/56A	2	0.3	80	2.7 to 5.5	80	Each	Yes	L/H	TPS2046/46A/56	0.65
TPS2047B/57A	3	0.3	80	2.7 to 5.5	160	Each	Yes	L/H	TPS2047/47A/57	0.90
TPS2048A/58A	4	0.3	80	2.7 to 5.5	160	Each	Yes	L/H	TPS2048/58	1.20
TPS2060/4	2	1.5	70	2.7 to 5.5	50	Each	Yes	L/H	—	1.20
TPS2061/5	1	1.1	70	2.7 to 5.5	43	Yes	Yes	L/H	—	0.60
TPS2062/6	2	1.1	70	2.7 to 5.5	50	Each	Yes	L/H	—	0.75
TPS2063/7	3	1.1	70	2.7 to 5.5	65	Each	Yes	L/H	—	0.90

Device	Application	Number of FETs	Switch Enable	Bus Power Indicator (BPMODE)	V _{IN}		Bus Powered		Self Powered		LDO Controller (A)	LDO	Price*
					(min) (V)	(max) (V)	r _{DS(on)} per FET (typ) (mΩ)	Current Limit (min) (A)	r _{DS(on)} per FET (typ) (mΩ)	Current Limit (min) (A)			
USB Power Controllers													
TPS2070	USB 4-port hub	8	L	1L	4.5	5.5	560	0.12	107	0.6	5 V, 3 A	3.3 V, 100 mA	2.55
TPS2071	USB 4-port hub	8	L	1H	4.5	5.5	560	0.12	107	0.6	5 V, 3 A	3.3 V, 100 mA	2.55
TPS2074	USB 4-port hub	8	L	1L	4.5	5.5	500	0.12	100	0.6	—	3.3 V, 100 mA	2.55
TPS2075	USB 4-port hub	8	L	1H	4.5	5.5	500	0.12	100	0.6	—	3.3 V, 100 mA	2.55
TPS2140	USB peripheral	1	L	—	2.7	5.5	70	0.1 & 1.2	—	—	—	Adj. 0.9 to 3.3 V, 250 mA	1.10
TPS2141	USB peripheral	1	L	—	4	5.5	70	0.1 & 1.2	—	—	—	Adj. 0.9 to 3.3 V, 250 mA	1.10
TPS2150	USB peripheral	1	H	—	2.7	5.5	70	0.1 & 1.2	—	—	—	Adj. 0.9 to 3.3 V, 250 mA	1.10
TPS2151	USB peripheral	1	H	—	4	5.5	70	0.1 & 1.2	—	—	—	Adj. 0.9 to 3.3 V, 250 mA	1.10
TPS2145	DSP, PDA	2	L	—	2.9	5.5	340	0.2	—	—	—	3.3 V, 200 mA	1.15
TPS2147	DSP, PDA	2	L	—	2.9	5.5	340	0.2	—	—	—	3.3 V, 200 mA	1.10
TPS2148	USB peripheral	2	L	—	2.9	5.5	340	0.2	—	—	—	3.3 V, 200 mA	0.99
TPS2149	USB 2-port hub	2	L	—	2.9	5.5	340	0.2	—	—	—	3.3 V, 200 mA	0.95
TPS2155	DSP, PDA	2	H	—	2.9	5.5	340	0.2	—	—	—	3.3 V, 200 mA	1.15
TPS2157	DSP, PDA	2	H	—	2.9	5.5	340	0.2	—	—	—	3.3 V, 200 mA	1.10
TPS2158	USB peripheral	2	H	—	2.9	5.5	340	0.2	—	—	—	3.3 V, 200 mA	0.99
TPS2159	USB 2-port hub	2	H	—	2.9	5.5	340	0.2	—	—	—	3.3 V, 200 mA	0.95

*Suggested resale price in U.S. dollars in quantities of 1,000. Please check www.ti.com for the most current pricing information.



Design Considerations

PCI Express® takes the best features and ideas behind PCI and combines them with more than 10 years of industry “lessons learned.” The result is a robust, scalable, flexible, cost-effective I/O interconnect that will serve the industry for the next 10-15 years.

Key Features

- PCI Express architecture is an industry standard high-performance, general-purpose serial I/O interconnect designed for use in enterprise, desktop, mobile, communications and embedded platforms.
- It is PCI-compatible by using the established PCI software programming models. PCI Express facilitates a smooth transition to new hardware and allows software to evolve and leverage the advantages of PCI Express features.
- Gen I has a scalable bandwidth of 16 Gigabytes-per-second at its initial signaling rate of 2.5GHz. In the future, Gen II promises much higher transfer rates using higher frequency signaling technologies.
- Supports multiple interconnect widths via 1, 2, 4, 8, 12, 16 and 32 lane configurations aggregated to match application bandwidth needs.
- Serves new and innovative, hot-plug/hot-swap add-in card and module devices.
- Delivers unique, advanced features such as Power Management, Quality of Service and other native functions not available in other I/O architectures.

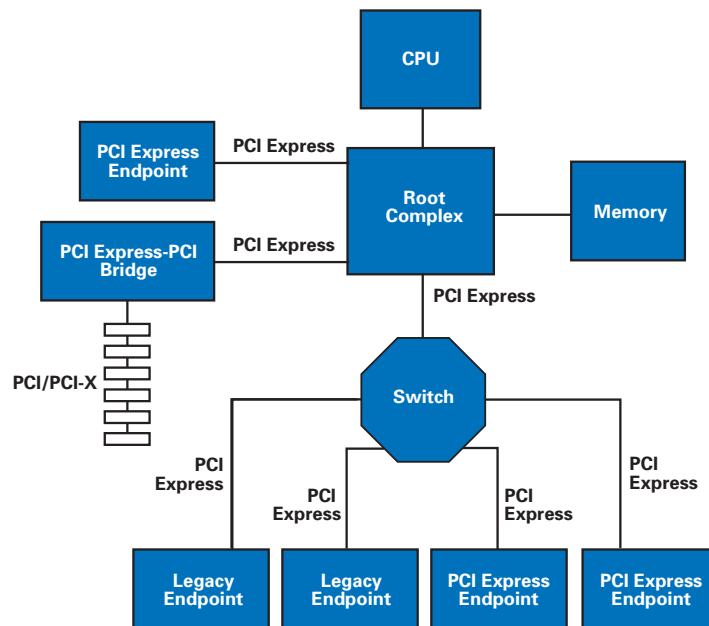
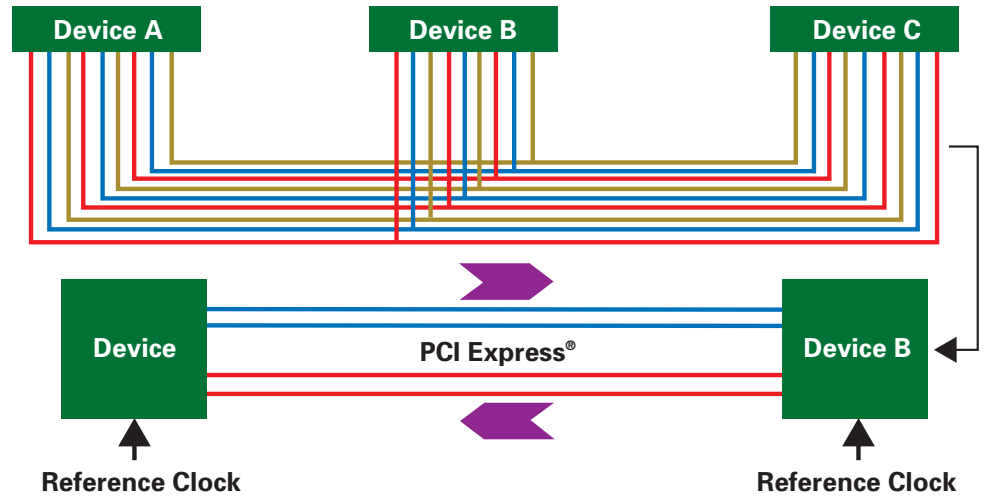

- #### Device Classifications
- Root Complex
 - Switch
 - PCI/PCI-X
 - Bridge
 - Legacy Endpoint
 - Endpoint

PCI Express® topology.

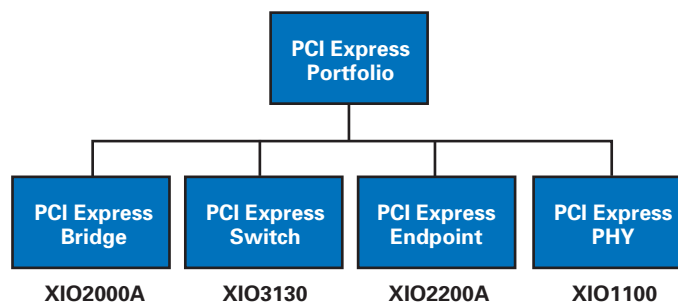

Current TI PCI Express® portfolio.



PCI Express® Bridge Chip XIO2000A

Get samples, datasheets, EVMs and app reports at: www.ti.com/sc/device/XIO2000A

TI's PCI Express bridge chip, the XIO2000A, is an industry first. It is designed for seamless migration from the legacy PCI to the PCI Express interface. It bridges an x1 PCI Express bus to a 32-bit, 33/66-MHz PCI bus capable of supporting up to six PCI devices downstream. The XIO2000A fully supports PCI Express rates of 2.5 Gbps. Its architecture supports the PCI 2.3 interface. The chip's design enables PC and I/O add-on card manufacturers to begin transitioning to native PCI Express technology while preserving compatibility with existing PCI system software and firmware.

Key Features

- Compliant with PCI Express to PCI/PCI-X Bridge Specification Revision 1.0
- Compliant with PCI Express Base Specification 1.0a
- Compliant with PCI Local Bus Specification rev 2.3
- Utilizes 100 MHz differential PCI Express Common Reference Clock or 125 MHz Single-Ended Reference Clock
- Full PCI Local Bus 66 MHz/32-bit Throughput
- Wake/Beacon Event Support
- Robust Architecture to Minimize Latency

Key Benefits

- Built-in adaptive receiver equalizer
 - Improves jitter tolerance thereby reliably increasing PCB trace, or cable length, supported by the XIO2000
- Seven buffered PCI clock outputs (33 MHz or 66 MHz)
 - Reduces external components, costs and premium board space
- 32-bit secondary PCI bus with 33-MHz or 66-MHz clocking option
 - Customizes to meet the needs of high-performance or low-power applications
- Proven compatibility with various PCI Express chipsets and PCI add-in cards
 - Rigorous field testing with major root complex device and numerous PCI add-in cards
- Compact footprint
 - Allows placement in ExpressCard and mini-PCI cards in limited board space
- Advanced power management features
 - Software programmable and hardware autonomous power management features for low-power applications such as ExpressCard

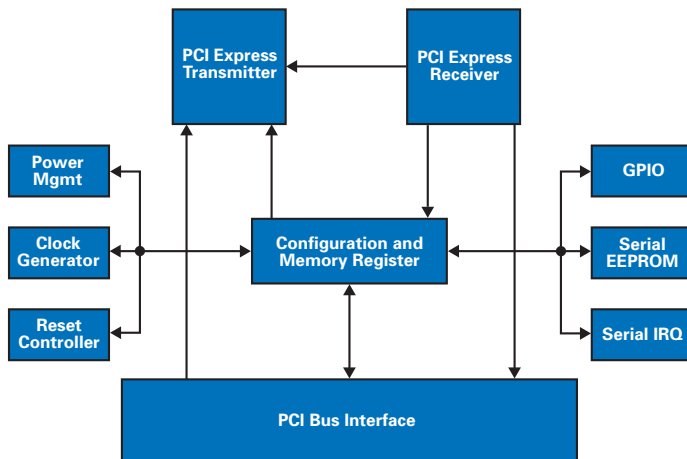

XIO2000A functional block diagram.

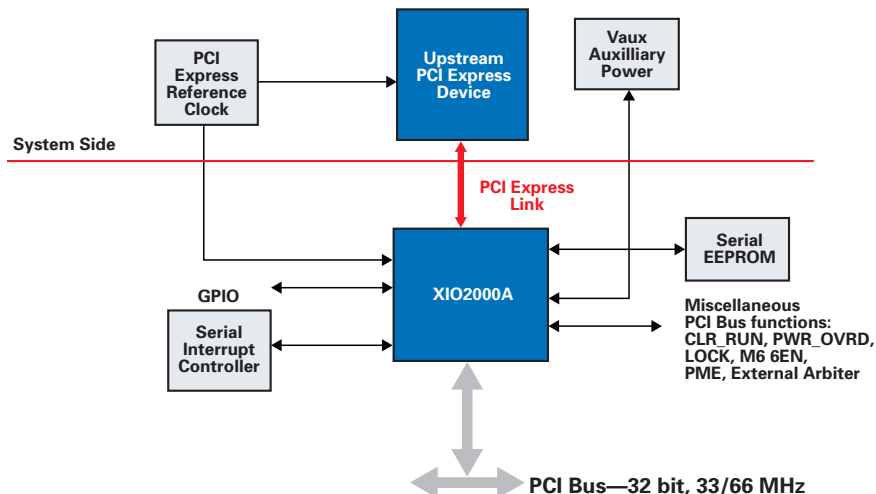

Typical system implementation.



x1 PCI Express® to 1394a OHCI Bridge XIO2200A

Get samples, datasheets, EVMs and app reports at:

www.ti.com/sc/device/XIO2200A

Key Features

- x1 PCI Express Primary Interface
- Supports two 1394a ports
- Fully-Compliant with 1394 Open Host Controller Interface Specification, Revision 1.1
- ExpressCard Reference Design supports two 1394a ports
- Internal dedicated PCI bus operates at 32-bit, 66 MHz
- Compact Footprint, 176-Ball, GGW MicroStar™ BGA or Lead-Free 176-Ball, ZGW MicroStar BGA

Key Benefits

- One-chip solution for 1394a ExpressCards
- Advanced power management features
- Software-programmable and hardware-autonomous power management
- Supports low-power applications such as ExpressCard
- Compact footprint, 176-ball MicroStar BGA
- EEPROM configuration allows a global unique ID for the 1394 fabric to load

Target Market

- ExpressCards
- PC Add-In Cards
- PC Motherboards

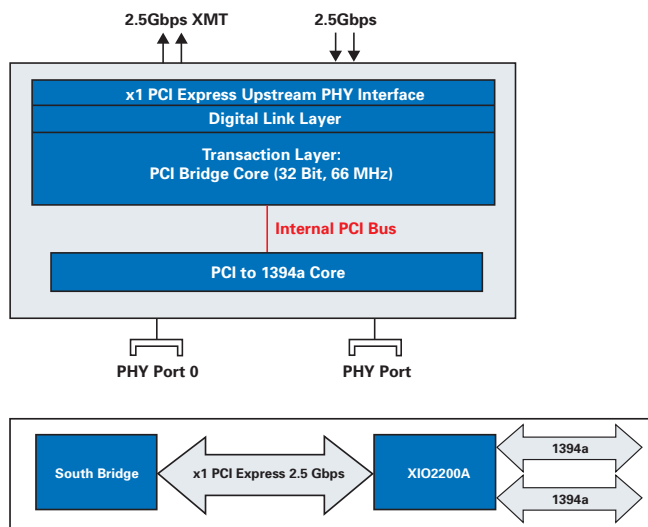

ExpressCard reference design.

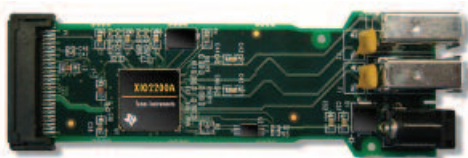

4-Lane, 4-Port PCI Express Switch XIO3130

PREVIEW*

www.ti.com/sc/pci-e

*Expected release 1Q 2007

TI's XIO3130 is an integrated PCI Express fan-out switch solution with one upstream x1 port and three downstream x1 ports. This high-performance, integrated solution provides the latest in PCI Express switch technology. It features cut-through architecture and integrated reference clock buffers for downstream ports. The XIO3130 is fully-compliant with the PCI Express Base Specification Rev. 1.1. It supports Advanced Error Reporting as defined in the PCI Express base specifications and is backwards-compatible with the PCI Local Bus Specification, Rev. 2.3.

Key Features

- PCI Express fan-out switch with x1 upstream port and three x1 downstream ports
- Fully compliant with PCI Express Base Specification, Rev. 1.1
- Cut-through architecture
- Built-in Adaptive Equalizer in each of the four ports
- Wake-event and Beacon support
- Support for D1, D2, D3hot, and D3cold
- Active State Power Management (ASPM)
- Uses both L0s and L1
- Low power PCI Express transmitter mode (pre-emphasis disabled)
- Integrated AUX Power Switch drains VAUX power only when main power is "off"
- Integrated Hot-Plug Support
- Integrated REFCLK Buffers for Switch Downstream Ports
- Advanced Error Reporting to assist with System Debug Tools
- 3.3V Multifunction I/O pins (e.g. for Hot-Plug status-and-control, or General Purpose I/Os)
- Listed in PCI-SIG Compliance List

Target Market

The primary purpose of the XIO3130 as a fan-out device is efficiently expanding the chipset's computing resources to multiple I/O ports and enhancing system functionality and flexibility. Target applications for the XIO3130 include PCs, servers, storage, industrial control and backplane.

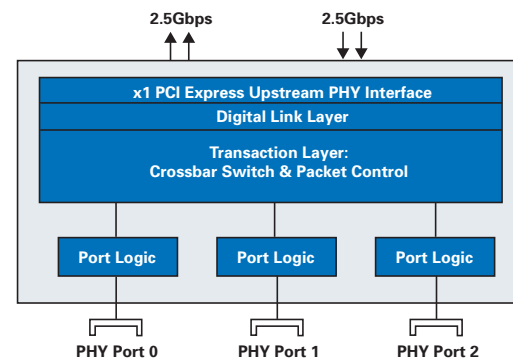



PCI Express PHY XIO1100

Get samples, datasheets, EVMs and app reports at: www.ti.com/sc/device/XIO1100

The XIO1100 is a PCI Express PHY, compliant with the PCI Express Base Specification Revision 1.1 that interfaces the PCI Express Media Access Layer (MAC) to a PCI Express serial link. It uses a modified version of the “PHY Interface for the PCI Express” (PIPE) interface also referred to as a TI-PIPE interface. The TI-PIPE interface is a pin-configurable interface that can be configured as either a 16-bit or an 8-bit interface.

- The 16-bit TI-PIPE interface is a 125 MHz 16-bit parallel interface, a 16 bits output bus (RXDATA) being clocked by the RXCLK output clock, and a 16-bits Input bus (TXDATA) being clocked by the TXCLK input clock. Both buses are clocked using Single Data Rate (SDR) clocking in which the data transitions are on the rising-edge of the associated clock.
- The 8-bit TI-PIPE interface is a 250 MHz 8-bit parallel interface, an 8-bit output bus (RXDATA) being clocked by the RXCLK output clock, and an 8-bit input bus (TXDATA) being clocked by the TXCLK input clock. Both buses are clocked using Double Data Rate (DDR) clocking where the data transitions on both the clock's rising-edge and falling-edge.

The XIO1100 PHY interfaces to a 2.5Gbps PCI Express serial link with a transmit differential pair (TXP and TXN) and a receive differential pair (RXP and RXN). Incoming data at the XIO1100 PHY receive differential pair (RXP and RXN) is forwarded to the MAC on the RXDATA output bus. Data received from the MAC on the TXDATA input bus is forwarded to the XIO1100 PHY transfer differential pair (TXP and TXN).

The XIO1100 is also responsible for handling the 8B/10B encoding/decoding of the outgoing data. In addition, XIO1100 can recover/interpolate the clock on the receiver side based on the transitions guaranteed by the use of the 8B/10B mechanism and supply this to the receive side of the data link layer logic. In addition to the TI-PIPE Interface, the XIO1100 has some TI proprietary side-band signals some customers may wish to use to take advantage of additional low-power state features (for example, disabling the PLL during the L1 power state) of the XIO1100.

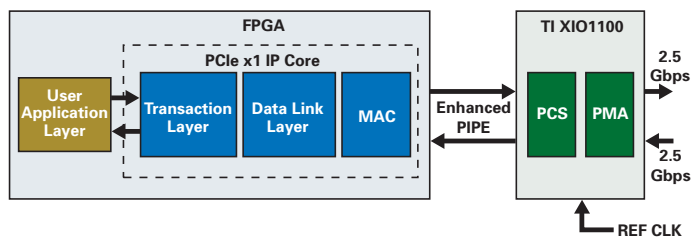

Low-cost FPGA-based PCI Express® solution.

Key Benefits

- XIO1100 is TI's Third-Generation PHY
 - Passed PCI SIG Workshop #49
 - v1.0a and v1.1 compliant
 - Proven PCI Express Compatibility and Interoperability
- Source-Synchronous (SS) Clocking
 - Without SS clocking and running at 125 MHz the interface must be tuned to the center capture window
 - Painful and not robust
 - XIO1100 is SS in BOTH RX and TX directions which makes positioning I/O capture window easy to identify and robust
 - SS approach works great from design without need for experimental tuning
- Flexible MAC Interface
 - Selectable 8-bit or 16-bit Parallel Interface
 - 16-bit: 125MHz rising-edge clocked
 - Can use low-cost FPGAs
 - 8-bit: 125MHz rising-and-falling edge clocked (DDR)
 - No need for extra clock buffer needed to generate 250MHz
- Flexible Digital I/O Power Supply
 - 1.5V or 1.8V
 - Only two supply voltages needed: 3.3V and 1.5V
- Support for two PCI Express Reference Clocks
 - 100 MHz differential for normal system clock designs
 - 125 MHz single-ended for asynchronous clocking designs

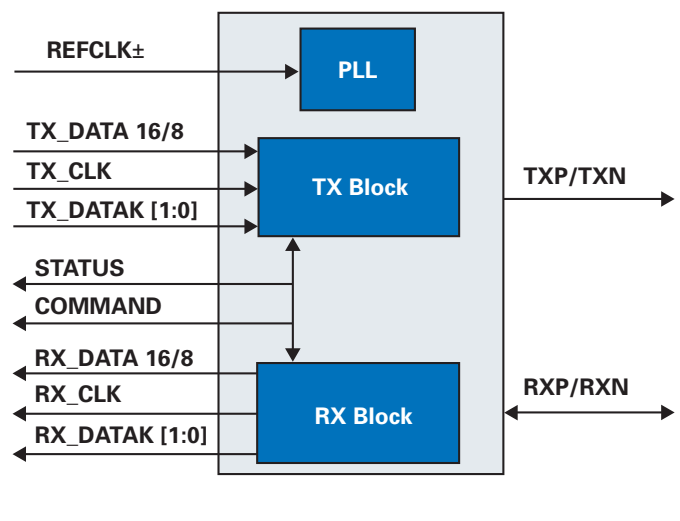

XIO1100 functional block diagram.



Design Considerations

Peripheral Component Interconnect (PCI) is an interconnection system between a micro-processor and attached devices in which expansion slots are spaced closely for high-speed operation. A PCI-to-PCI bridge is a high-performance connection path between two PCI buses that allows bridge transactions to occur concurrently on both buses. Burst-mode transfers maximize data throughput while the two bus traffic paths through the bridge act independently. In future systems, many PCI bus structures will be replaced by

the new serial PCI Express architecture. TI is actively developing a portfolio of PCI Express products to address this new market.

Key Features

- Two 32-bit, 33- or 66-MHz buses
- Configurable for PCI power-management interface specification
- CompactPCI hot-swap functionality
- 3.3-V core logic with 3.3- to 5-V PCI signaling compatibility
- Intel® bridge compatibility
- Transparent bridging

Technical Information

Capabilities

- TI's PCI2050B is a 32-bit, 66-MHz bridge with internal two-tier arbitration for up to 9 secondary bus masters and support for an external secondary bus. There are independent read/write buffers for each direction and 10 secondary PCI clock outputs.

Functionality

- The PCI2250 is a 33-MHz bridge similar to the PCI2050B but supports 4 secondary bus masters and 5 secondary PCI clock outputs.

PCI Bridges

PCI2040
PCI2050B
PCI2250
PCI2060

PCI bridge family of products.

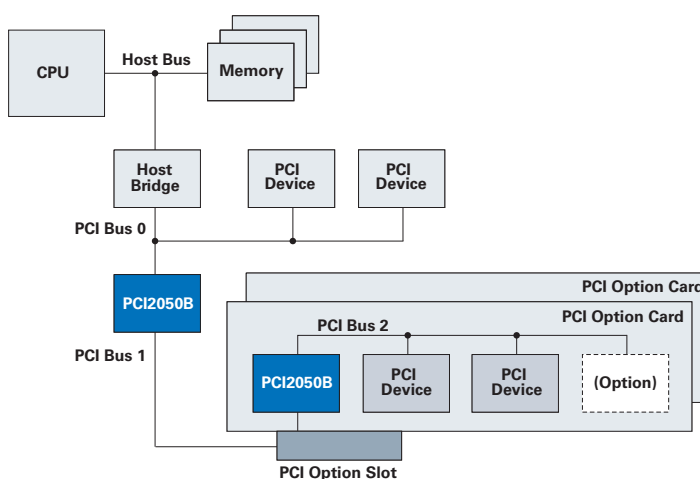

Typical PCI-to-PCI bridge system application.

Selection Guide

Device	Intel-Compatible Part No.	Speed (MHz)	Expansion Interface (bits)	Hot-Swap	MicroStar BGA™ Packaging	Voltage (V)	Package(s)	Description	Price*
PCI Bridges									
PCI2040	—	33	—	—	Yes	3.3, 5	144 BGA, 144 LQFP	PCI-to-DSP bridge controller, compliant with Compact PCI Hot-Swap Specification	10.55 1.00
PCI2050B	21150bc	66	32	Yes	Yes	3.3, 5	208 LQFP, 208 QFP, 257 BGA	32-bit, 66-MHz, 9-master PCI-to-PCI bridge	9.50
PCI2250	21152ab	33	32	Friendly	No	3.3, 5	176 LQFP, 160 QFP	32-bit, 33-MHz PCI-to-PCI bridge, Compact PCI hot-swap friendly, 4-master	6.10
PCI2060	—	66	32	Yes	Yes	3.3, 5	257 BGA	32-bit, 66-MHz, 9-master, asynchronous PCI-to-PCI bridge	9.50

*Suggested resale price in U.S. dollars in quantities of 1,000.

Resources For a complete list of resources (evaluation modules, data sheets and application notes), visit interface.ti.com

Literature Number	Description
Application Notes	
SCPA029A	Adding Debounce Logic to /HSSwitch Terminal
SLLA067	Comparing Bus Solutions
SCPA027	Connecting ENUM Terminal to an External Open-Drain Buffer
SCPA030	Interfacing the PCI2040 to the TMS320VC5420 DSP
SPRA679	Texas Instruments TMS320VC5409/5421 DSP to PCI Bus



Design Considerations

ExpressCard Power Switches

The TPS2231 and TPS2236 ExpressCard power interface switches provide the total power management solution required by the ExpressCard specification. The TPS2231 and TPS2236 ExpressCard power interface switches distribute 3.3 V, AUX and 1.5 V to the ExpressCard socket. Each voltage rail is protected with integrated current-limiting circuitry. The TPS2231 supports systems with single-slot ExpressCardj34 or ExpressCardj54 sockets. The TPS2236 supports systems with dual-slot ExpressCard sockets.

PCMCIA/CardBus Power Switches

Standard PC cards require that V_{CC} be switched between ground, 3.3 V and 5 V, while V_{PP} is switched between ground, 3.3 V, 5 V and 12 V. CardBay sockets have the standard requirements for V_{CC} , but require ground, 3.3 V and 5 V to V_{PP} , and ground, 1.8 V or 3.3 V to V_{CORE} . Other PC card applications may simply not need 12 V or V_{PP} while still having the standard requirements for V_{CC} . Therefore, consider the voltage requirements of the application when selecting a PCMCIA power switch.

Current-Limiting Power Switches

Power switches are used to intelligently turn power on and off, while providing fault protection. They are useful anywhere controlled allocation of power is needed to circuit blocks, modules, add-in cards or cabled connections. They are ideal for power sequencing or segmentation.

To minimize voltage drop, select devices with the lowest $r_{DS(on)}$ or Drain to Source on-resistance.

Power MUX ICs

Power MUX ICs are designed to transition from a main power supply to an auxiliary source when the main supply shuts down (e.g. switching from battery operation to a wall adapter).

TPS2211A

- Fully integrated V_{CC} and V_{PP} switching for single-slot PC card interface
- Low $r_{DS(on)}$
- 3.3-V low-voltage mode
- Short-circuit and thermal protection
- Compatible with 3.3-V, 5-V and 12-V PC cards

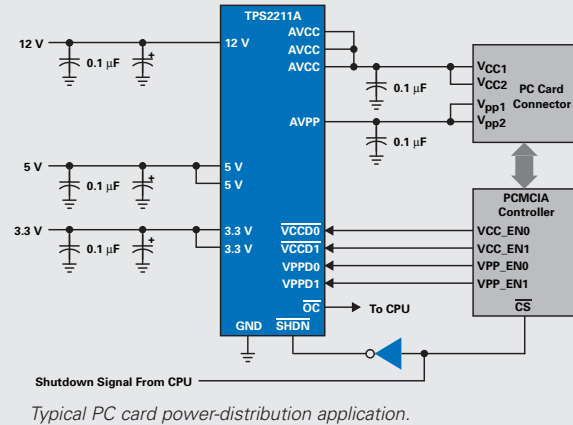

Power Distribution Devices Family of Products

Current-Limiting Power Switch ICs

		Current Limit (min) (A)							
		0.22	0.3	0.345	0.66	0.7	1.1	1.65	2.2
Fault Reporting									
Quad	—	TPS2048A/58A	TPS2048/58 ¹	—	TPS2044/54 ²	TPS2044A/54A	—	—	—
		TPS2095/6/7			TPS2044B/54B	TPS2085/6/7			
Triple	—	TPS2047B/57A	TPS2047/57 ¹	—	TPS2043/53 ²	TPS2043A/53A	—	—	—
					TPS2043B/53B	TPS2042/52 ²			
Dual	—	TPS2046B/56A	TPS2046/56 ¹	—	TPS2042A/52A	TPS2042B/52B	—	—	—
		TPS2090/1/2			TPS2080/1/2	TPS2041/51 ²	TPS2022/32	TPS2023/33	TPS2024/34
Single	TPS2020/30 ¹	TPS2045A/55A	TPS2045/55 ¹	TPS2021/31 ¹	TPS2041A/51A	TPS2041B/51B			
No Fault Reporting									
Single	TPS2010A	—	—	TPS2011A	—	TPS2012A	TPS2013A	—	—

¹Nemko recognized. ²UL and Nemko recognized.

PCMCIA/CardBus Power Switch Matrix ICs

		Current Limit (min) (A)			
		0.3	0.7	1.0	2.5
3.3 V, 5 V, 12 V, V_{PP}					
Dual	—	—	—	TPS2224(A), TPS2226(A), TPS2204A, TPS2206A, TPS2205	—
Single	TPS2212	—	—	TPS2204A, TPS2210A, TPS2211(A), TPS2220A, TPS2220B	TPS2231
No 12 V					
Dual	—	—	—	TPS2223A	TPS2236
Single	—	TPS2044B/54B	—	—	—
No V_{PP}					
Dual	—	TPS2044B/54B	—	—	—

Power MUX ICs

Configuration	Device	I_{OUT} (mA)	Transition	Comments
	TPS2100/1	IN1: 500, IN2: 10	Manual	SOT-23, 0 to 70°C
	TPS2102/3	IN1: 500, IN2: 100	Manual	SOT-23, 0 to 70°C
	TPS2104/5	IN1: 500, IN2: 100	Manual	SOT-23, -40 to 85°C
IN1 IN2	TPS2110A	Adj. 310 to 750	Auto/Manual	TSSOP
	TPS2111A	Adj. 630 to 1250	Auto/Manual	TSSOP
	TPS2112A	Adj. 310 to 750	Auto	TSSOP, Status pin
	TPS2113A	Adj. 630 to 1250	Auto	TSSOP, Status pin
	TPS2114A	Adj. 310 to 750	Auto/Manual	TSSOP, Status pin
	TPS2115A	Adj. 630 to 1250	Auto/Manual	TSSOP, Status pin

ExpressCard Power Switch ICs

Device	Ports	3V $r_{DS(on)}$ (m Ω)	Interface	Current Limit (Min) (A)
TPS2231	1	45	Parallel	2.5
TPS2236	2	45	Parallel	2.5



Selection Guide

Device	Number of FETs	I _{OS} (min) (A)	r _{DS(on)} (mΩ)	V _{IN} Range (V)	Supply Current (μA)	OC Logic Output	OT Logic Output	Enable	Predecessor	Price*
Current-Limiting Power Switch ICs										
TPS2010A	1	0.22	30	2.7 to 5.5	73	No	No	L	TPS2010	0.75
TPS2011A	1	0.66	30	2.7 to 5.5	73	No	No	L	TPS2011	0.75
TPS2012A	1	1.1	30	2.7 to 5.5	73	No	No	L	TPS2012	0.75
TPS2013A	1	1.65	30	2.7 to 5.5	73	No	No	L	TPS2013	0.75
TPS2020/30	1	0.22	33	2.7 to 5.5	73	Yes	Yes	L/H	—	1.05
TPS2021/31	1	0.66	33	2.7 to 5.5	73	Yes	Yes	L/H	TPS2014	1.05
TPS2022/32	1	1.1	33	2.7 to 5.5	73	Yes	Yes	L/H	TPS2015	1.05
TPS2023/33	1	1.65	33	2.7 to 5.5	73	Yes	Yes	L/H	—	1.05
TPS2024/34	1	2.2	33	2.7 to 5.5	73	Yes	Yes	L/H	—	1.05
TPS2041B/51B	1	0.7	70	2.7 to 5.5	43	Yes	Yes	L/H	TPS2041/51/41A/51A	0.50
TPS2042B/52B	2	0.7 ea	70	2.7 to 5.5	50	Each	Yes	L/H	TPS2042/52/42A/52A	0.70
TPS2043B/53B	3	0.7 ea	70	2.7 to 5.5	65	Each	Yes	L/H	TPS2043/53/43A/53A	0.90
TPS2044B/54B	4	0.7 ea	70	2.7 to 5.5	75	Each	Yes	L/H	TPS2044/54/44A/54A	1.00
TPS2045A/55A	1	0.3	80	2.7 to 5.5	80	Yes	Yes	L/H	TPS2045/55	0.60
TPS2046B/56A	2	0.3 ea	80	2.7 to 5.5	80	Each	Yes	L/H	TPS2046/46A/56	0.65
TPS2047B/57A	3	0.3 ea	80	2.7 to 5.5	160	Each	Yes	L/H	TPS2047/47A/57	0.90
TPS2060/4	2	1.5 ea	70	2.7 to 5.5	50	Each	Yes	L/H	—	1.20
TPS2061/5	1	1.1	70	2.7 to 5.5	43	Yes	Yes	L/H	—	0.60
TPS2062/6	2	1.1 ea	70	2.7 to 5.5	50	Each	Yes	L/H	—	0.75
TPS2063/7	3	1.1 ea	70	2.7 to 5.5	65	Each	Yes	L/H	—	0.90
TPS2048A/58A	4	0.3 ea	80	2.7 to 5.5	160	Each	Yes	L/H	TPS2048/58	1.20
TPS2080/1/2 ¹	2	0.7 ea	80	2.7 to 5.5	85	Yes	Yes	2H, 1L/1H, 2L	—	0.65
TPS2085/6/7 ¹	4	0.7 ea	80	2.7 to 5.5	85	Yes	Yes	4H, 2L/2H, 4L	—	1.05
TPS2090/1/2 ¹	2	0.3 ea	80	2.7 to 5.5	85	Yes	Yes	2H, 1L/1H, 2L	—	0.65
TPS2095/6/7 ¹	4	0.3 ea	80	2.7 to 5.5	85	Yes	Yes	4H, 2L/2H, 4L	—	1.05

Device	Interface	Number of Ports	3.3-V r _{DS(on)} (typ) (mΩ)	5.0-V r _{DS(on)} (typ) (mΩ)	I _{OS} (min) (A)	Predecessor	Price*
PCMCIA/CardBus Switch Matrix ICs							
TPS2210A	3-line Serial	1	85	95	1	—	0.85
TPS2204A	3-line Serial	2	85	95	1	TPS2214/14A	1.95
TPS2220B	3-line Serial	1	85	95	1	TPS2220A	0.85
TPS2223A	3-line Serial	2	85	95	1	—	1.80
TPS2224A	3-line Serial	2	85	95	1	TPS2214/14A	1.95
TPS2226A	3-line Serial	2	85	95	1	TPS2206, TPS2216/16A	2.10
TPS2206A	3-line Serial	2	85	95	1	TPS2206, TPS2216/16A	2.10
TPS2205	8-line Parallel	2	70	100	1	TPS2201	2.90
TPS2211A	4-line Parallel	1	70	57	1	TPS2211	0.75
TPS2212	4-line Parallel	1	160	160	0.3	—	1.45
TPS2231	4-line Parallel	1	68	—	2.5	—	1.00
TPS2044B or 54B	Parallel	1 or 2	80	80	0.7	TPS2044/44A, TPS2054/54A	1.00
TPS2221	Interface Parallel	1	72	97	1	—	1.85
TPS2228	Interface Serial	2	72	97	1	—	3.10

Device	Number of Inputs	IN1 r _{DS(on)} (mΩ)	IN2 r _{DS(on)} (mΩ)	IN1 Output Current (mA)	IN2 Output Current (mA)	IN1 Supply Current (μA)	IN2 Supply Current (μA)	Input Voltage Range (V)	Transition Time		Transition	Price*
									IN1 to IN2 (μs)	IN2 to IN1 (μs)		
Power MUX ICs												
TPPM0301/2	3	—	—	400	400	2500	250	3 to 5.5	—	—	Autoswitch	1.60
TPPM0303	3	—	—	250	250	2500	250	3 to 5.5	—	—	Autoswitch	1.07
TPS2100/1	2	250	1300	500	10	10	0.75	2.7 to 4.0	4	900	L/H enable	0.59
TPS2102/3	2	250	1300	500	100	14	0.75	2.7 to 4.0	3	700	L/H enable	0.69
TPS2104/5	2	250	1300	500	100	18	0.75	2.7 to 5.5	3	700	L/H enable	0.85
TPS2110A/2A/4A	2	120	120	312 to 750	312 to 750	85	85	2.8 to 5.5	40	40	Autoswitch	0.70
TPS2111A/3A/5A	2	84	84	625 to 1250	625 to 1250	85	85	2.8 to 5.5	40	40	Autoswitch	0.70

¹Can be configured as power MUX ICs.

*Suggested resale price in U.S. dollars in quantities of 1,000.

New products are listed in bold red.



Overview

IEEE 1394 high-speed interconnection enables simple, low-cost, high-bandwidth real-time data connectivity between many types of electronic equipment. As a multimedia network standard, 1394 is ideally suited for consumer electronics, computers and peripherals. It is also ideal for situations that benefit from true peer-to-peer operation and maximum flexibility. 1394 is self-configuring, has strong power management/distribution capabilities and robust error-detection that make it a leading choice in control applications, especially those that also need to accommodate streaming multimedia.

The new 1394b technology enables higher performance (up to 3.2 Gbps), longer distance (up to 100 meters) and a variety of cable media to fit any application (STP, UTP, POF and GOF), making it ideal for home networking and high-speed data transfer applications. For example, in long-haul applications such as home networking, 1394b is capable of 100 Mbps over 100 meters of unshielded twisted pair Category 5 cable (called CAT5 or UTP5). For high-speed applications, TI offers a 1394b chip set that enable speeds up to 800 Mbps for applications such as video-on-demand or backing up a RAID array. TI 1394b is backward compatible to 1394a.

Design Considerations

Physical-Layer Selection Issues

- The 1394 PHY layer should support the minimum number of nodes or ports required by the end product. Having two ports permits spanning to other devices on the bus through daisy-chaining. Three or more nodes enable branching or hub capabilities.
- Will the end product need DC isolation at the 1394 interface? The cable doesn't provide a DC-isolated path from node to node. In cases where there's a possibility for the various equipment connected across 1394 to be at different ground potentials or different power domains, the grounds may need to be isolated from each other to prevent excessive currents and noise. However, the ground signal on the 1394 cable must not be DC-isolated from the PHY power-distribution ground plane. Thus when DC isolation between units is required at the 1394 interface, it is frequently performed at the PHY- and link-layer interfaces—often through the use of special I/O cells that allow for capacitive coupling of the PHY-link signals.
- While the EIA-775 specification requires a minimum speed of 200 Mbps at the 1394 interface, using 400-Mbps PHYs is recommended. Slower nodes present on the bus can be a source of speed traps. Almost all 1394 silicon available today is already 400-Mbps capable.
- The suspend/resume feature of the PHY layer lets two currently inactive ports achieve low-power states while maintaining their connection status. It also permits them to quickly resume operation as soon as they detect an applied port bias voltage.

Link-Layer Selection Issues

- What kind of data needs to be transferred? Some link controllers are designed to implement specific data protocols over 1394, such as the serial bus protocol 2 (SBP-2) for mass storage or IEC 61883-4 for MPEG-2 transport, and some are designed as general purpose.
- What is being interfaced to 1394? If the system has PCI, consider one of the PCI/OHCI links. Applications involving streaming compressed audio/video most likely need a link from the iCelLynx family. Other TI links have interfaces for external processors/memory or are dedicated for a peripheral function (camera/storage).
- For audio/visual (A/V) applications, different types of A/V data require different formatting and transmission methods on 1394. Specifically identifying which types of A/V to be supported is fundamental to choosing the right 1394 chip set for the digital set-top box (DSTB) or digital TV (DTV) design. Standards define how to carry MPEG-2 transport streams in both digital video broadcasting (DVB) format and in DirecTV format, which have different packetization schemes.
- Another aspect of the link layer that should be considered is the amount of data-buffer memory supported. Typically, the more bandwidth an application requires, or the more simultaneous isochronous/asynchronous traffic that needs to be supported, the larger the buffer memories must be.

- As the number of simultaneous isochronous channels present goes up, or the bit rate of an individual stream increases, the receive buffer needs to be larger.

Technical Information

- 1394-1995 is an IEEE designation for a high-performance serial bus. A revision to this standard has been published as IEEE 1394a-2000, and clarifies and adds to portions of the IEEE 1394-1995 standard. The 1394b standard increases the speed of 1394 to 800, 1600 and 3200 Mbps, as well as providing new connection options such as plastic optical fiber (POF), glass optical fiber (GOF) and UTP-5. This serial bus defines both a backplane (for example, VME, FB+) physical layer and a point-to-point, cable-connected virtual bus. The backplane version operates at 12.5, 25 or 50 Mbps, whereas the cable version supports data rates of 100, 200, 400, 800 and 1,600 Mbps across the cable medium supported in the current standard. Both versions are totally compatible at the link layer and above. The interface standard defines transmission method, media and protocol.
- Applications of the cable version are the integration of I/O connectivity of personal computers, peripherals, and consumer electronics using a low-cost, scalable, high-speed serial interface. The 1394 standard provides services such as real-time I/O and live connect/disconnect capability for devices including storage (HDD, CD-ROM, CDRW, MO, ZIP, RAID, SAN, etc.), printers, scanners, cameras, set-top boxes, HDTVs and camcorders.



Technical Information (Continued)

- Applications of the cable version are the integration of I/O connectivity of personal computers, peripherals, and consumer electronics using a low-cost, scalable, high-speed serial interface. The 1394 standard provides services such as real-time I/O and live connect/disconnect capability for devices including storage (HDD, CD-ROM, CDRW, MO, ZIP, RAID, SAN, etc.), printers, scanners, cameras, set-top boxes, HDTVs and camcorders.

Key Features

- Real-time streaming of audio and video
- High-speed: up to 400 Mbps with IEEE 1394-1995 and 1394a-2000, up to 1, 2 and 4 Gbps with 1394b
- Plug-and-play hot pluggable
- Peer-to-peer communication
- Small, durable and flexible cable and connectors
- Memory-mapped architecture
- Seamless I/O interconnect

1394b Advantages

- Faster: speeds from 800 Mbps to 3200 Mbps
- Longer distances: 100 meters with GOF and CAT5; 50 meters with POF
- TI1394b is bi-lingual: communicates in 1394a and 1394b modes
- More cabling options: STP, CAT5, POF, GOF
- More efficient: BOSS arbitration
- More user-friendly: loop-free build allows any topology and redundancy

Selection Guide

Device	Ports	Voltage (V)	Data Rate (Mbps)	Package(s)	Description	Price*
1394 Physical Layer Controllers						
TSB14AA1A	1	3.3	up to 100	48 TQFP	IEEE 1394-1995, 3.3-V, 1-port, 50/100-Mbps, backplane PHY controller	5.90
TSB41AB1	1	3.3	up to 400	48/64 HTQFP	IEEE 1394a 1-port cable transceiver/arbitrator	1.50
TSB41AB2	2	3.3	up to 400	64 HTQFP	IEEE 1394a 2-port cable transceiver/arbitrator	1.85
TSB41AB3	3	3.3	up to 400	80 HTQFP	IEEE 1394a 3-port cable transceiver/arbitrator	3.00
TSB41BA3B	3	3.3	up to 400	80 TQFP	1394b-2002 3-port physical layer device	6.50
TSB41LV04A	4	3.3	up to 400	80 HTQFP	IEEE 1394a 4-port cable transceiver/arbitrator	6.50
TSB41LV06A	6	3.3	up to 400	100 HTQFP	IEEE 1394a 6-port cable transceiver/arbitrator	6.40
TSB81BA3D	3	1.8, 3.3	up to 800	80 HTQFP	High-performance 1394b s800 3-port cable transceiver/arbitrator	5.55

*Suggested resale price in U.S. dollars in quantities of 1,000.



IEEE 1394b 3-Port Cable Transceiver/Arbiter TSB81BA3D

Get samples, datasheets and app reports at: www.ti.com/sc/device/TSB81BA3D

Key Features

- Compliant with IEEE 1394b-2002, IEEE 1394a-2000 and 1394-1995 standards
- 3 Bilingual 1394 Ports
 - 1394b (Beta) Mode at s400 and s800
 - 1394a (Data Strobe -DS) Mode at s100, s200 and s400
- Interoperable with link layer controllers using 3.3-V supplies and other 1394 PHYs using 1.8-V, 3.3-V and 5-V supplies

Applications

- Storage devices
- Consumer electronics
- 1394B PC ports

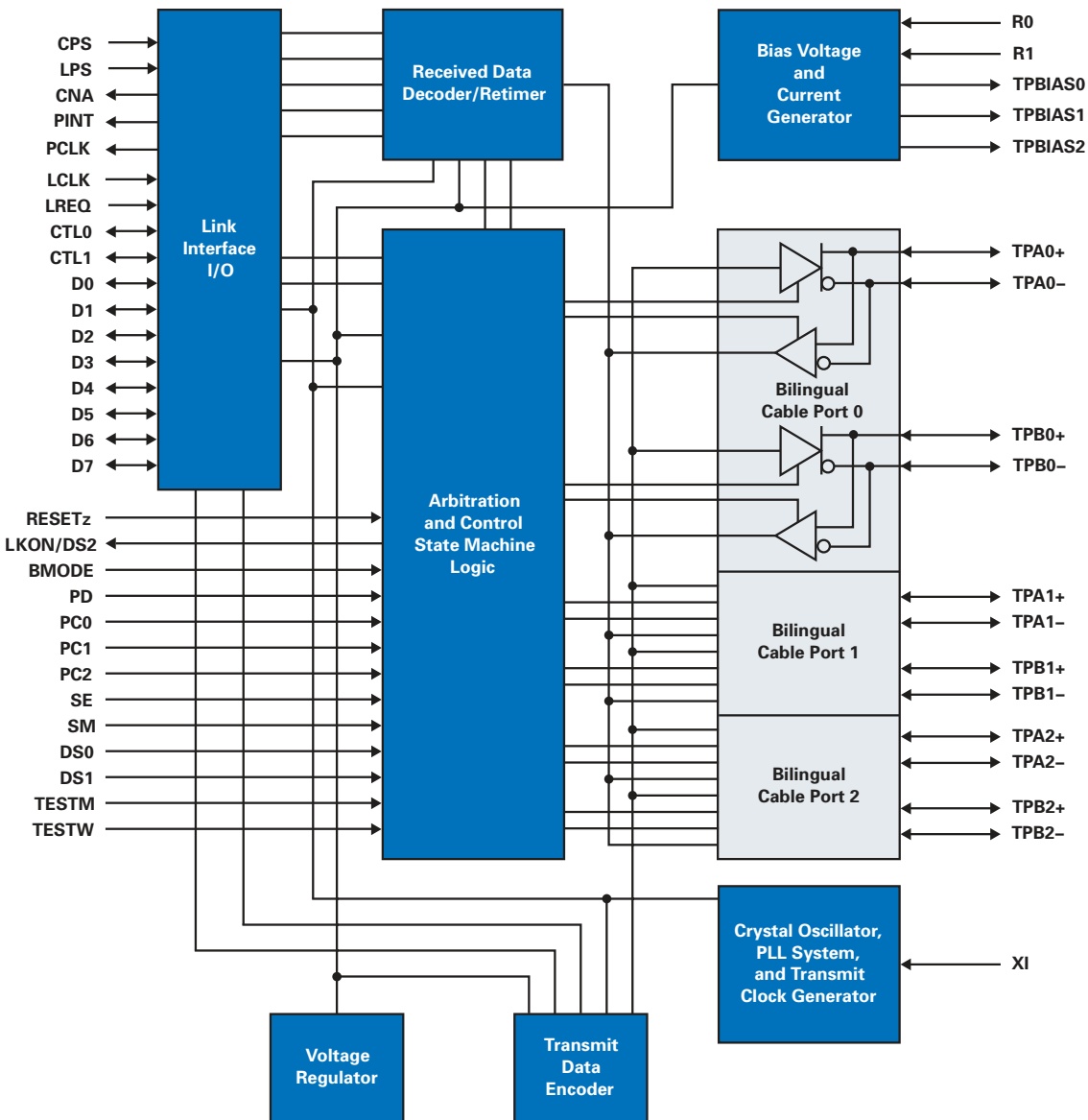

TSB81BA3D block diagram.



Design Considerations

Primary

Speed — The speed of the GTLP family in parallel backplanes is 4x that of traditional logic. Optimized output edge-rate control (OEC™) circuitry allows clock frequencies in excess of 100 MHz in high-performance system backplane applications.

Voltage Range — The GTLP family operates at 3.3 V and with 5-V tolerant LVTTTL inputs/outputs and can operate in a mixed-voltage environment. GTLP acts as LVTTTL -to-GTLP bi-directional translators with 5 V tolerance on the LVTTTL port.

Drive — The GTLP family provides ± 24 -mA drive on the A-Port (LVTTTL side) and the choice of medium (50 mA) or high (100 mA) drive on the B-Port (GTLP side). This offers flexibility in matching the device to backplane length, slot spacing and termination resistance.

Signal Integrity—TI-OPC™ — Overshoot protection circuitry was designed specifically for the GTLP family and incorporated into the GTLP outputs. TI-OPC actively clamps any overshoots that are caused by improperly terminated backplanes, unevenly distributed cards or empty slots. OEC on the rising and falling edge of the GTLP outputs reduces line reflections and extra EMI, improving overall signal integrity.

True Live Insertion — GTLP backplane drivers allow for Level 3 isolation and true live-insertion capability. Level 1 isolation, partial power-down: I_{OFF} circuitry within the device prevents damage by limiting the current flowing from an energized bus when the device V_{CC} goes to zero. Level 2 isolation, hot insertion: both I_{OFF} and power-up 3-state (PU3S) circuitry allow insertion or removal of a board into a backplane without powering

down the host system and without suspending signaling. Level 3 isolation, live insertion: for live insertion both I_{OFF} and PU3S circuitry are needed and the board I/Os must be precharged to mid-swing levels prior to connector insertion/removal.

Secondary

Compatibility — GTLP provides an easy migration path from traditional backplane logic like ABT, FCT, LVT, ALVT, LVC and FB+.

Portfolio — TI offers the broadest GTLP portfolio in the industry, with both high-drive (100 mA) and medium-drive (50 mA) devices.

Packaging — TI offers GTLP in a low-profile, fine-pitch BGA package (LFBGA) and in a quad flat no-lead package (QFN) for higher performance and the ultimate reduction in board-space requirements.

Single Bit Representation of a Multipoint Parallel Backplane

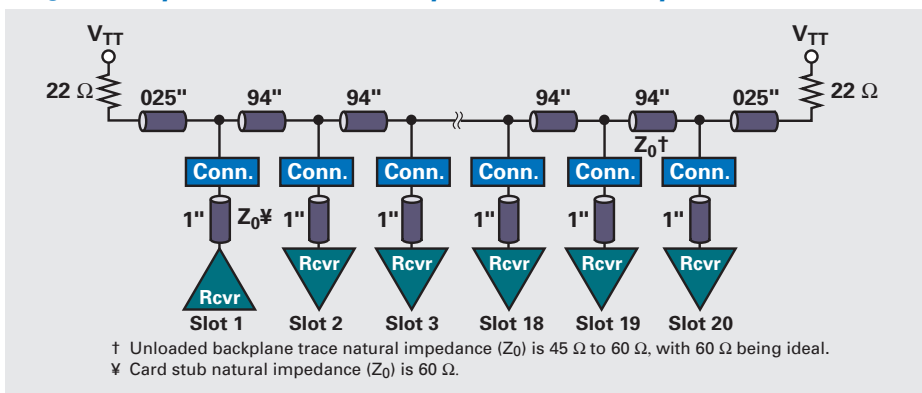

Signal Integrity: TI vs Competition

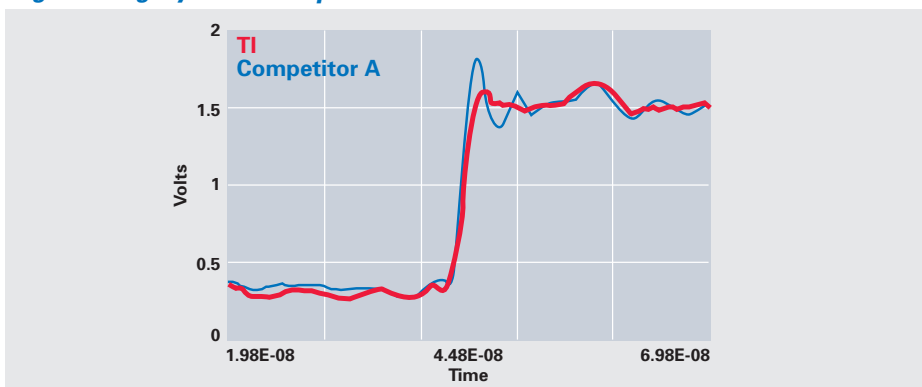



GTLP Selection Guide

Device	Description	Price*
SN74GTLP1394	2-Bit LVTTTL-to-GTLP Adjustable-Edge-Rate Bus Xcvr w/ Split LVTTTL Port, Feedback Path and Selectable Polarity	2.09
SN74GTLP1395	Two 1-Bit LVTTTL/GTLP Adjustable-Edge-Rate Bus Xcvrs w/ Split LVTTTL Port, Feedback Path and Selectable Polarity	2.09
SN74GTLP2033	8-Bit LVTTTL-GTLP Adjustable-Edge-Rate Registered Transceiver w/ Split LVTTTL Port and Feedback Path	5.17
SN74GTLP2034	8-Bit LVTTTL-GTLP Adjustable-Edge-Rate Registered Transceiver w/ Split LVTTTL Port and Feedback Path	5.17
SN74GTLP21395	Two 1-Bit LVTTTL/GTLP Adjustable-Edge-Rate Bus Xcvrs w/ Split LVTTTL Port, Feedback Path and Selectable Polarity	2.09
SN74GTLP22033	8-Bit LVTTTL-GTLP Adjustable-Edge-Rate Registered Transceiver w/ Split LVTTTL Port and Feedback Path	5.17
SN74GTLP22034	8-Bit LVTTTL-GTLP Adjustable-Edge-Rate Registered Transceiver with Split LVTTTL Port and Feedback Path	5.17
SN74GTLP817	GTLP-to-LVTTTL 1-to-6 Fanout Driver	1.95
SN74GTLP1612	18-Bit LVTTTL-to-GTLP Adjustable-Edge-Rate Universal Bus Transceiver	5.25
SN74GTLP1616	17-Bit LVTTTL-to-GTLP Adjustable-Edge-Rate Universal Bus Transceiver w/ Buffered Clock Outputs	5.25
SN74GTLP1627	18-Bit LVTTTL-to-GTLP Bus Xcvr w/Source Synchronous Clock Outputs	5.63
SN74GTLP1645	16-Bit LVTTTL-to-GTLP Adjustable-Edge-Rate Bus Transceiver	3.30
SN74GTLP1655	16-Bit LVTTTL-to-GTLP Adjustable-Edge-Rate Universal Bus Transceiver	5.25
SN74GTLP16612	18-Bit LVTTTL-to-GTLP Universal Bus Transceiver	4.58
SN74GTLP16912	18-Bit LVTTTL-to-GTLP Universal Bus Transceiver	4.88
SN74GTLP16916	17-Bit LVTTTL-to-GTLP Universal Bus Transceiver w/ Buffered Clock Outputs	4.88
SN74GTLP16927	18-Bit LVTTTL-to-GTLP Bus Transceiver w/Source Synchronous Clock Outputs	7.70
SN74GTLP16945	16-Bit LVTTTL-to-GTLP Bus Transceiver	2.75
SN74GTLP306	8-Bit LVTTTL-to-GTLP Bus Transceiver	2.42
SN74GTLP3245	32-Bit LVTTTL-to-GTLP Adjustable-Edge-Rate Bus Transceiver	5.83
SN74GTLP32912	36-Bit LVTTTL-to-GTLP Universal Bus Transceiver	7.50
SN74GTLP32916	34-Bit LVTTTL-to-GTLP Universal Bus Transceiver w/ Buffered Clock Outputs	7.50
SN74GTLP32945	32-Bit LVTTTL-to-GTLP Bus Transceiver	4.29

*Suggested resale price in U.S. dollars in quantities of 1,000.

Resources For a complete list of resources (evaluation modules, data sheets and application notes), visit interface.ti.com

Literature Number	Description
Application Notes	
SCEA017	GTLP in BTL Applications
SCEA019	Texas Instruments GTLP Frequently Asked Questions
SCEA026	Logic in Live-Insertion Applications With a Focus on GTLP
SCEA022	Achieving Maximum Speed on Parallel Buses With Gunning Transceiver Logic
SCBA015A	Fast GTLP Backplanes With the GTLP1655
Other Literature	
SCYT126	Advanced Bus Interface Logic Selection Guide



Design Considerations

Backward compatibility — The VMEH22501/A improves the performance up to 8X of the VMEbus™ without making changes to existing hardware.

Standard Specification — The VMEH22501/A are referenced by the 2eSST VITA 1.5 spec as a device that provides excellent signaling at 40-Mbps data rate.

Increased Noise Immunity — The ± 50 -mV input threshold allows the VMEH22501/A to provide clean signaling under harsh environments.

Full Live Insertion—This device is fully specified for live-insertion applications using I_{OFF} , power-up 3-state and BIAS V_{CC} .

Speed/Signal Integrity—High-speed backplane operation is a direct result of the improved OEC circuitry that has been tested on the standard VME backplane. Furthermore, signal integrity is not compromised with higher speed operation.

Technical Information

- TI's SN74VMEH22501/A are specifically designed for the VMEbus technology. The device is an 8-bit universal bus transceiver (UBT) with two bus transceivers. It provides incident switching on the 21-slot VMEbus backplane, thus providing data signaling rates of up to 40 Mbps—an 8X improvement over the VME64 standard.

Highlights

- Ability to transmit data on the VMEbus up to 2eSST protocol speed is an improvement over VME64.
- Incident wave switching allows for higher performance on the VMEbus compared to conventional logic that depends on reflective wave switching.

VME Parametric Table

Parameter Name	SN74VMEH22501	SN74VMEH2501A
Voltage Nodes (V)	3.3	3.3
V_{CC} Range (V)	3.15 to 3.45	3.15 to 3.45
Input Level	LVTTTL	LVTTTL
Output Level	LVTTTL	LVTTTL
Output Drive (mA)	–48/64	–48/64
No. of Outputs	10	10
Logic	True	True
Static Current (mA)	30	30
t_{pd} max (ns)	8.9	8.9
T_A	0° C to 85° C	–40° C to 85° C

Resources For a complete list of resources (evaluation modules, data sheets and application notes), visit interface.ti.com

Literature Number	Description
Application Notes	
SCEA028	VMEH22501 in 2eSST and Conventional VME Backplane Applications
Other Literature	
SCYB009	VME Application Clip



Clock Selection by Speed and Signaling Type

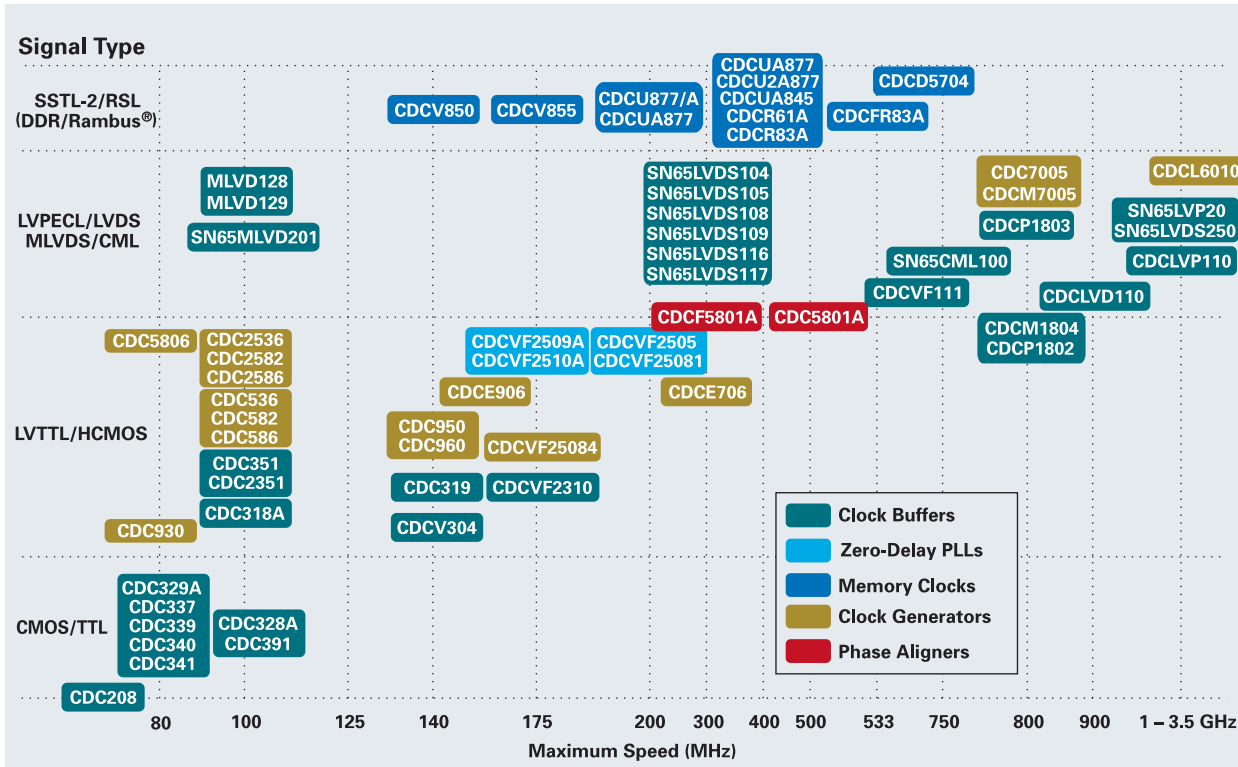

Clock Selection by Number of Outputs and Signaling Type

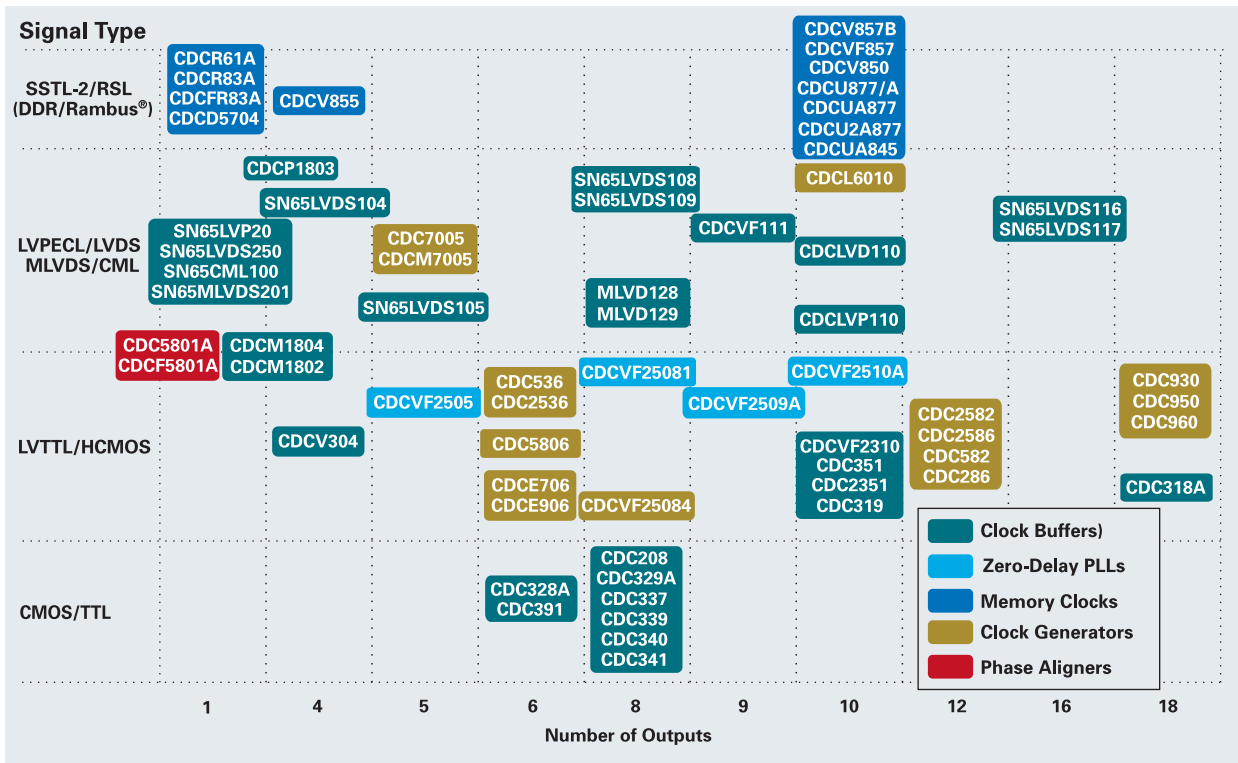



The following products have similar functionality:

Part Number	TI Replacement
AGERE	
BDG1A	TB5D1M
BDG1A	TB5D2H
BDGLA	TB5D2H
BPNGA	TB5D1M
BRF1A	TB5R1
BRF2A	TB5R1
BRS2A	TB5R2
BRS2B	TB5R2
BTF1A	TB5T1

Part Number	TI Replacement
AGILENT	
HDMP1636/1646	TNETE2201B

Part Number	TI Replacement
ALLEGRO	
A2525	TPS2051A
A2526	TPS2052A
A2535	TPS2041A
A2536	TPS2042A

Part Number	TI Replacement
ANALOG DEVICES (ADI)	
ADM1485	SN75LBC176A*
ADM1486	SN65HVD1176*
ADM3485E	SN75HVD10*
ADM483E	SN65HVD3082E
ADM483E	SN75LBC176A*
ADM485	SN65HVD3085E*
ADM485	SN65HVD485E*
ADM485	SN75LBC176A*
ADM485	SN75176B*
ADM488	SN75LBC179A*
ADM489	SN75LBC180A*

Part Number	TI Replacement
CMP	
CMPWR025	TPS210x

Part Number	TI Replacement
CYPRESS	
AN-213x	TUSB3410

Part Number	TI Replacement
EUREKA	
EP600	TL16C550C

Part Number	TI Replacement
EXAR	
ST16C2450	TL16C452
ST16C2550	TL16C552A
ST16C2550	TL16C752B*
ST16C2552	TL16C552A*
ST16C450	TL16C450*
ST16C452	TL16C452*
ST16C550	TL16C550B
ST16C550	TL16C550C
ST16C552	TL16C552
ST16C552	TL16C552A
ST16C552A	TL16C552
ST16C552A	TL16C552A
ST16C554	TL16C554A
ST16C554D	TL16C554
ST16C554D	TL16C554A
ST16C580	TL16C550C

Part Number	TI Replacement
EXAR (cont.)	
ST16C654	TL16C754B
ST16C654D	TL16C754B
ST68C554	TL16C554A
XR16L2750	TL16C752B
XR16L2751	TL16C752B
XR16L2752	TL16C752B
XR16L651	TL16C750
XR16L784	TL16C754B

Part Number	TI Replacement
FAIRCHILD SEMICONDUCTOR	
FIN1001	SN65LVDS1*
FIN1002	SN65LVDS2*
FIN1017	SN65LVDS1*
FIN1018	SN65LVDS2*
FIN1019	SN65LVDS180
FIN1022	SN65LVCP22*
FIN1025	SN65LVDS9638
FIN1026	SN65LVDS9637
FIN1027	SN65LVDS9638*
FIN1028	SN65LVDS9637*
FIN1031	SN65LVDS31*
FIN1032	SN65LVDS32*
FIN1047	SN65LVDS047*
FIN1048	SN65LVDS048A*
FIN1049	SN65LVDS049
FIN1101	SN65LVDS100
FIN1102	SN65LVCP22
FIN1104	SN65LVDS125
GTLP1616	SN74GTLP1616
GTLP16612	SN74GTLP1612
GTLP16612	SN74GTLP16612
GTLP16T1655	SN74GTLP1655
GTLP18T612	SN74GTLP16912
GTLP6C817	SN74GTLP817
GTLP8T306	SN74GTLP306

Part Number	TI Replacement
FTDI	
FT232BM	TUSB3410

Part Number	TI Replacement
GOLDSTAR	
GM16C550	TL16C550B*
GM16C550	TL16C550C*

Part Number	TI Replacement
HYNIX (LG)	
GD75232	GD75232*

Part Number	TI Replacement
IMP	
Ei16C450	TL16C450
Ei16C550	TL16C550C
Ei16C552	TL16C552
Ei16C552	TL16C552A
Ei16C554	TL16C554
Ei16C554	TL16C554A

Part Number	TI Replacement
IMPX	
IMP2525	TPS2051A
IMP2525A	TPS2051A
IMP2526	TPS2052A

Part Number	TI Replacement
INFINEON	
TLE6250	SN65HVD251
TLE6250	SN65HVD1050

Part Number	TI Replacement
INTEL	
21150AB/AC	PCI2050*
21150BC	PCI2050B*
21152	PCI2250*

Part Number	TI Replacement
INTERSIL	
HIN211	SN75LBC241
HIN211E	SN75LBC241
HIN232	MAX232*
HIN232E	MAX232
HIN241	SN75LBC241
HIN241E	SN75LBC241
ICL232	MAX232*
ICL3221	MAX3221*
ICL3221E	MAX3221
ICL3222	MAX3222*
ICL3222E	MAX3222
ICL3223	MAX3223*
ICL3223E	MAX3223
ICL3232	MAX3232*
ICL3232E	MAX3232
ICL3238	MAX3238*
ICL3238E	MAX3238
ICL3243	MAX3243*
ICL3243E	MAX3243
ISL1483	SN65HVD3082E*
ISL1483	SN65LBC184*
ISL1487	SN65HVD06*
ISL1487	SN65HVD21*
ISL1487E	SN65HVD06*
ISL1487E	SN65HVD21*
ISL1487L	SN65HVD3082E*
ISL1487L	SN65LBC184*
ISL8483	SN65HVD3082E*
ISL8485	SN65HVD06*
ISL8485	SN65HVD21*
ISL8488	SN65LBC179A*
ISL8489	SN65LBC180A*
ISL8490	SN65LBC179A*
ISL8491	SN65LBC180A*

Part Number	TI Replacement
LINEAR TECHNOLOGY CORP. (LTC)	
LT1030	LT1030
LT1081	MAX232
LT1181A	MAX232
LT1381	MAX232

* Drop-in, pin-compatible devices



The following products have similar functionality:

Part Number	TI Replacement	Part Number	TI Replacement	Part Number	TI Replacement
LINEAR TECHNOLOGY CORP. (LTC) (cont.)		MAXIM (cont.)		MAXIM (cont.)	
LT1785	SN75LBC184*	MAX3044	SN75LBC172A*	MAX491	SN75LBC180*
LTC1472	TPS2211A	MAX3045B	SN75LBC172A*	MAX491E	SN75LBC180A*
LTC1480	SN75HVD11*	MAX3050	SN65HVD251*	MAX625	TPS2044A/54A
LTC1481	SN75LBC176A*	MAX3053	SN65HVD251	MAX780	TPS2205
LTC1482	SN75LBC176A*	MAX3053	SN65HVD251*	MAX869L	TPS2024/34
LTC1483	SN75LBC176A*	MAX3057	SN65HVD251*	MAX890L	TPS2022/32
LTC1484	SN75LBC176A*	MAX3082	SN65HVD3082E*	MAX9110	SN65LVDS1*
LTC1485	SN65LBC176A*	MAX3082E	SN65HVD3082E*	MAX9111	SN65LVDS2*
LTC1487	SN65HVD3082E*	MAX3085	SN65HVD3085E*	MAX9112	SN65LVDS9638*
LTC1487	SN75HVD07*	MAX3085E	SN65HVD3085E*	MAX9113	SN65LVDS9637*
LTC1518	SN75LBC173A*	MAX3088	SN65HVD3088E*	MAX9115	SN65LVDS2
LTC1519	SN75LBC175A*	MAX3088E	SN65HVD3088E*	MAX9121	SN65LVDS048A*
LTC1685	SN65HVD1176*	MAX3093E	SN75LBC173A*	MAX9122	SN65LVDT048A*
LTC1686	SN75LBC179A*	MAX3095E	SN75LBC175A*	MAX9123	SN65LVDS047*
LTC1687	SN75LBC180A*	MAX3221	MAX3221*	MAX9124	SN65LVDS31*
LTC1688	SN75LBC172A*	MAX3221E	MAX3221	MAX9125	SN65LVDS32*
LTC1689	SN75LBC174A*	MAX3222	MAX3222*	MAX9126	SN65LVDT32*
LTC1690	SN75LBC179A*	MAX3222E	MAX3222	MAX9130	SN65LVDS2
LTC1796	SN65HVD251*	MAX3223	MAX3223*	MAX9152	SN65LVCP22
LTC485	SN65HVD3085E*	MAX3223E	MAX3223	MAX9155	SN65LVDS100
LTC485	SN65HVD485E*	MAX3232	MAX3232*	MAX9156	SN65LVDS100
LTC485	SN75LBC176A*	MAX3232E	MAX3232	MAX9159	SN65LVDS9637*
LTC485	SN75176B*	MAX3238	MAX3238*	MAX9163	SN65MLVD201
LTC486	SN75172*	MAX3238E	MAX3238	MAX9164	SN65LVDS180
LTC486	SN75ALS172A*	MAX3243	MAX3243*	MAX9169	SN65LVDS104*
LTC486	SN75LBC172A*	MAX3243E	MAX3243	MAX9170	SN65LVDS105*
LTC487	SN75174*	MAX3362	SN75HVD10*	MAX9171	SN65LVDS2*
LTC487	SN75ALS174A*	MAX3443E	SN75LBC184*	MAX9172	SN65LVDS9637
LTC487	SN75LBC174A*	MAX3463	SN65HVD1176*	MAX9173	SN65LVDS048A
LTC488	SN75173*	MAX3464	SN65HVD3082E*	MAX9174	SN65LVDS122
LTC488	SN75ALS173*	MAX3464	SN75HVD05*	MAX9175	SN65LVDS122
LTC488	SN75LBC173A*	MAX3483	SN75HVD12*	MAX9177	SN65LVCP22
LTC489	SN75175*	MAX3483E	SN75HVD12*	MAX9178	SN65LVDS047*
LTC489	SN75ALS175*	MAX3485	SN75HVD11*	MAX9179	SN65LVDS348*
LTC489	SN75LBC175A*	MAX3485E	SN75HVD11*	MAX9180	SN65LVDS100
LTC490	SN75LBC179A*	MAX3486	SN75HVD12*	MAX9181	SN65LVDS100
LTC491	SN75LBC180A*	MAX3486E	SN75HVD12*	MAX9205	SN65LV1023*
		MAX481/E	SN65HVD3088E*	MAX9206	SN65LV1021*
		MAX481	SN75LBC176*	MAX9207	SN65LV1224*
		MAX481E	SN75LBC176A*	MAX9208	SN65LV1212*
		MAX483/E	SN65HVD3082E*	MAX9320	SN65LVCP23
		MAX483	SN75LBC176*	MAX9320A	NS65LVCP23
		MAX483E	SN75LBC176A*	MAX9321B	SN65LVDS101
		MAX485/E	SN65HVD3085E*	MAX9374	SN65LVDS100
		MAX485	SN75LBC176*	MAX9374A	SN65LVDS100
		MAX485E	SN75LBC176A*	MAX9375	SN65LVDS101
		MAX487	SN75HVD07*		
		MAX487	SN75LBC182*	MICROCHIP	
		MAX487E	SN65HVD3082E*	MCP2551	SN65HVD251*
		MAX488	SN75LBC179*	MCP2120	TIR1000
		MAX488E	SN75LBC179A*		
		MAX489	SN75LBC180*		
		MAX489E	SN75LBC180A*		
		MAX490	SN75LBC179*		
		MAX490E	SN75LBC179A*		

* Drop-in, pin-compatible devices



The following products have similar functionality:

Part Number	TI Replacement
MICREL	
MIC2505	TPS2024/34
MIC2506	TPS2042A/52A
MIC2507	TPS2044A/54A
MIC2514	TPS210x
MIC2524	TPS2044A/54A
MIC2525	TPS2041A/51A
MIC2526	TPS2042A/52A
MIC2527	TPS2044A/54A
MIC2563A	TPS2205
MIC2564A	TPS2216A
NATIONAL SEMICONDUCTOR	
DS14185	SN75185*
DS14196	SN75196
DS1487	SN75HVD06*
DS1488	SN75188
DS1489	SN75189
DS14C232	MAX232
DS14C88	SN75C188
DS14C89A	SN75C189A
DS36276	SN75HVD05*
DS3695	SN65HVD3088E*
DS3695	SN75LBC176A*
DS3695	SN75ALS176*
DS3695	SN75176B*
DS3697	SN75179*
DS3697	SN75ALS179*
DS3697	SN75LBC179*
DS36C278	SN75HVD06*
DS36C279	SN75HVD06*
DS36C280	SN75HVD06*
DS36F95	SN75LBC176*
DS485	SN65HVD3088E*
DS485	SN75LBC176A*
DS485	SN75ALS176*
DS485	SN75176B*
DS75176B	SN75LBC176A*
DS75176B	SN75ALS176*
DS75176B	SN75176B*
DS90CP04	SN65LVDS250
DS90CP22	SN65LVCP22*
DS90CR215	SN65LVDS95*
DS90CR216	SN65LVDS96*
DS90CR283	SN65LVDS93*
DS90CR284	SN65LVDS94*
DS90LT012A	SN65LVDT2*
DS90LV001	SN65LVDS100*
DS90LV0101A	SN65MLVD201
DS90LV011A	SN65LVDS1*
DS90LV012A	SN65LVDS2*
DS90LV017	SN65LVDS1*
DS90LV017A	SN65LVDS1*
DS90LV018A	SN65LVDS2*
DS90LV018A	SN65LVDT2*
DS90LV019	SN65LVDS179
DS90LV027A	SN65LVDS9638*

Part Number	TI Replacement
NATIONAL SEMICONDUCTOR (cont.)	
DS90LV028A	SN65LVDS9637*
DS90LV031	SN65LVDM31*
DS90LV031	SN65LVDS31*
DS90LV031A	SN65LVDM31*
DS90LV031A	SN65LVDS31*
DS90LV031B	SN65LVDM31*
DS90LV031B	SN65LVDS31*
DS90LV032	SN65LVDS32*
DS90LV032A	SN65LVDS32*
DS90LV047	SN65LVDS047*
DS90LV047A	SN65LVDS047*
DS90LV048	SN65LVDS048A*
DS90LV048A	SN65LVDS048A*
DS90LV049	SN65LVDS049*
DS90LV1021	SN65LV1021*
DS90LV1023	SN65LV1023*
DS90LV1023	SN65LV1023A*
DS90LV1212A	SN65LV1212*
DS90LV1224	SN65LV1224A*
DS92LV010A	SN65MLVD200*
DS92LV010A	SN65MLVD201*
DS92LV010A	SN65MLVD204*
DS92LV010A	SN65MLVD206*
DS92LV090	SN65LVDM976
DS92LV090	SN65LVDM977
DS92LV090A	SN65LVDM976
DS92LV090A	SN65LVDM977
DS92LV1010	SN65MLVD201
DS92LV1021	SN65LV1021*
DS92LV1021	SN65LV1023A*
DS92LV1021	SN65LVDS151
DS92LV1023	SN65LV1023A*
DS92LV1212A	SN65LV1212*
DS92LV1224	SN65LV1224B*
DS92LV16	TLK2521
DS92LV18	TLK2521
DS92LV222	SN65LVCP22
DS92LV222	SN65LVDM22
DS92LV222A	SN65LVCP22
DS92LV222A	SN65LVDM22
DS96173	SN75173*
DS96173	SN75ALS173*
DS96173	SN75LBC173A*
DS96174	SN75174*
DS96174	SN75ALS174A*
DS96174	SN75LBC174A*
DS96175	SN75LBC175A*
DS96175	SN75ALS175*
DS96175	SN75175*
DS96176	SN65HVD3088E*
DS96176	SN75LBC176A*
DS96176	SN75ALS176*
DS96176	SN75176B*
DS9636	DS9636

Part Number	TI Replacement
NATIONAL SEMICONDUCTOR (cont.)	
DS96F174C	SN75174*
DS96F174C	SN75ALS174A*
DS96F174C	SN75LBC174A*
DS96F175C	SN75175*
DS96F175C	SN75ALS175*
DS96F175C	SN75LBC175A*
PC16550D	TL16C550B
PC16550D	TL16C550C*
PC16552D	TL16C552A
SC28L194	TL16C554A*
SC28L92	TL16C552A*
SC68C562C1A	TL16C552A*
ON SEMI	
MC100EP16	SN65LVDS100
MC100EP16	SN65LVDS101
MC1488	SN75188*
MC1489	SN75189*
MC1489A	SN75189A*
MC14C89AB	SN75C189A
MC3488A	UA9636A
OXFORD	
OXCF950	TL16PC564B
PERICOM	
PI7C8150A	PCI2050*
PI7C8150A	PCI2050B*
PI7C8152A	PCI2250*
PI90LV001	SN65LVDS1*
PI90LV019	SN65LVDS180
PI90LV02	SN65LVDS2*
PI190LV03	SN65LVDS100
PI90LV051	SN65LVDS051*
PI90LV179	SN65LVDS179*
PI90LV180	SN65LVDS180*
PI90LV3486	SN65LVDS3486*
PI90LV3487	SN65LVDS3487
PI90LV3487	SN65LVDS3487*
PI90LV9637	SN65LVDS9637*
PI90LV9638	SN65LVDS9638*
PI90LVB001	SN65LVDS1
PI90LVB010	SN65MLVD201
PI90LVB03	SN65LVDS100
PI90LVB047A	SN65LVDS047
PI90LVB180	SN65LVDM180*
PI90LVB387	SN65LVDS387
PI90LVB9638	SN65LVDS9638
PI90LVT02	SN65LVDS2*
PI90LVT02	SN65LVDT2*
PI90LVT048A	SN65LVDT348
PI90LVT3486	SN65LVDT3486*
PI90LVT3486	SN65LVDT3486B*
PI90LVT386	SN65LVDT386*
PI90LVT9637	SN65LVDT9637*

* Drop-in, pin-compatible devices



The following products have similar functionality:

Part Number	TI Replacement
PERICOM (cont.)	
PI90LVT9637	SN65LVDT9637B*
PI90LV017A	SN65LVDS1*
PI90LV018A	SN65LVDS2*
PI90LV019	SN65MLVD200*
PI90LV019	SN65MLVD201*
PI90LV019	SN65MLVD204*
PI90LV019	SN65MLVD206*
PI90LV022	SN65LVCP22
PI90LV022	SN65LVDS122
PI90LV027A	SN65LVDS9638*
PI90LV028A	SN65LVDS9637*
PI90LV031A	SN65LVDS31*
PI90LV032A	SN65LVDS32*
PI90LV047A	SN65LVDS047*
PI90LV048A	SN65LVDS048*
PI90LV050	SN65LVDS050*
PI90LV386	SN65LVDS386*
PI90LV387	SN65LVDS387*
PI90LVB022	SN65LVDM22
PI90LVB047A	SN65LVDM31
PI90LVB050	SN65LVDM050*
PI90LVB051	SN65LVDM051*
PI90LVB179	SN65LVDM179*
PI90LVB180	SN65MLVD202*
PI90LVB180	SN65MLVD203*
PI90LVB180	SN65MLVD205*
PI90LVB180	SN65MLVD207*

PHILIPS	
PCA82C250	SN65HVD251*
PCA82C251	SN65HVD251*
SC16C550	TL16C55C*
SC16C554	TL16C554*
SC16C554	TL16C554A*
SC16C650A	TL16C550
SC16C652	TL16C752
SC16C654	TL16C754
SC16C752	TL16C752B*
SC16C2550	TL16C752B
SC16C2552	TL16C752B
SC28L194	TL16C554A
SC28L91	TL16C550C
SC28L92	TL16C552A
SC68C562C1A	TL16C552A
SCC2691	TL16C450
SCC2692	TL16C452*
SCC68692	TL16C452*

Part Number	TI Replacement
PHILIPS (cont.)	
SCN2681	TL16C452*
TJA1040	SN65HVD1040*
TJA1050	SN65HVD1050*
PLX	
PCI6150	PCI2050*
PCI6150	PCI12050B*
PCI6140	PCI2250*
PROLIFIC	
PL-2303	TUSB3410
SEMTECH	
SC5825	TPS2041A/51A
SC5826	TPS2042A/52A
SILICON LABORATORIES	
CP2101	TUSB3410
CP2102	TUSB3410
SILICONIX/VISHAY	
Si9711	TPS2211A
Si9712	TPS2211A
SILICON SYSTEM	
73M550	TL16C550C*
SIPEX	
SP211	SN75LBC241
SP232A	MAX232
SP3222E	MAX3222
SP3222EB	MAX3222
SP3222EU	SNx5C3222
SP3223E	MAX3223
SP3223EB	MAX3223
SP3223EU	SNx5C3223
SP3232E	MAX3232
SP3232EB	MAX3232
SP3232EU	SNx5C3232
SP3238E	MAX3238
SP3243E	MAX3243
SP3243EB	MAX3243
SP3243EU	SNx5C3243
SP3481	SN75HVD11*
SP3483	SN75HVD12*
SP3485	SN75HVD11*
SP3494	SN75HVD10*
SP481	SN65HVD3088E*
SP481	SN75LBC176*
SP481	SN75ALS176*
SP481	SN75176B*
SP481E	SN65HVD3088E*

Part Number	TI Replacement
SIPEX (cont.)	
SP481E	SN75LBC176A*
SP481R	SN65HVD3088E*
SP483	SN65HVD3082E*
SP483	SN75LBC176*
SP483	SN75ALS176*
SP483	SN75176B*
SP483E	SN65HVD3085E*
SP483E	SN65HVD485E*
SP485	SN65HVD3088E*
SP485	SN75LBC176*
SP485	SN75ALS176*
SP485	SN75176B*
SP485E	SN65HVD3088E*
SP485E	SN75LBC176A*
SP486	SN75LBC172*
SP486E	SN75LBC172A*
SP487	SN75LBC174*
SP487E	SN75LBC174A*
SP488	SN75LBC173*
SP488A	SN75LBC173A*
SP488E	SN75LBC173A*
SP489	SN75LBC175*
SP489A	SN75LBC175A*
SP489E	SN75LBC175A*
SP490	SN75LBC179*
SP490E	SN75LBC179A*
SP491	SN75LBC180*
SP491E	SN75LBC180A*

Part Number	TI Replacement
STM	
ST232	MAX232*
ST3222	MAX3222*
ST3222E	MAX3222
ST3232	MAX3232*
ST3232E	MAX3232
ST3243	MAX3243*
ST3243E	MAX3243
ST75185	SN75185
ST75C185	SN75C185*

* Drop-in, pin-compatible devices



Device	Page	Device	Page	Device	Page	Device	Page	Device	Page	Device	Page
175	9, 12, 42	HVD23	12	PCI2040	33	SN65LVDS95/96	20-21	SN75LVDS82/83	20-21	TPS2063/7	28, 35
176B	12	HVD24	12	PCI2050B	33	SN65LVDS9637	6-7	SN75LVDS84A/86	20-21	TPS2070	27-28
ADM2209E	14	HVD30	12	PCI2060	33	SN65LVDS9638	6-7	SN75LVDT1422	20-21	TPS2071	27-28
ALS1177	12	HVD3082E	12	PCI2250	33	SN65LVP16/17	5	TB3R1	5	TPS2074	27-28
ALS1178	12	HVD3085E	12	SN65220	26	SN65LVP18/19	5	TB3R2	5	TPS2075	27-28
ALS176	12	HVD3088E	12	SN65240	26	SN65MLVD0	5, 42	TB5D1M	5	TPS2080/1/2	34-35
ALS180	12	HVD31	12	SN65C1154	15	SN65MLVD0047	9	TB5D2H	5	TPS2085/6/7	34-35
CDC208	42	HVD32	12	SN65C1406	15	SN65MLVD0080	9	TB5R1	5	TPS2090/1/2	34-35
CDC2351	42	HVD33	12	SN65C23243	14	SN65MLVD0082	9	TB5R2	5	TPS2095/6/7	34-35
CDC2536	42	HVD34	12	SN65C3221	14	SN65MLVD128	9	TB5R3	5	TPS2100/1	34-35
CDC2582	42	HVD35	12	SN65C3221E	14	SN65MLVD129	9	TB5T1	5	TPS2102/3	34-35
CDC2586	42	HVD379	12	SN65C3222	15	SN65MLVD2	9	TFF401	22	TPS2104/5	34-35
CDC286	42	HVD485E	12	SN65C3222E	14	SN65MLVD200A	9	TFF401A	22	TPS2110A/2A/4A	35
CDC318A	42	HVD50	12	SN65C3223	14	SN65MLVD201	9, 42	TFF403	22	TPS2111A/3A/5A	35
CDC319	42	HVD51	12	SN65C3223E	14	SN65MLVD202A	9	TFF410	22	TPS2140	28
CDC328A	42	HVD52	12	SN65C3232	14	SN65MLVD203	9	TFF501	22-23	TPS2141	28
CDC329A	42	HVD53	12	SN65C3232E	14	SN65MLVD204A	9	TFF503	22-23	TPS2145	28
CDC337	42	HVD54	12	SN65C3238	14	SN65MLVD205A	9	TFF510	22-23	TPS2147	28
CDC339	42	HVD55	12	SN65C3243	14	SN65MLVD206	9	TFF513	22-23	TPS2148	27-28
CDC340	42	ISO150	10	SN65CML100	4-5, 42	SN65MLVD207	9	TL145406	15	TPS2149	27-28
CDC341	42	ISO721	10	SN65HVD1050	18	SN65MLVD203	9	TL16C2550	16-17	TPS2150	28
CDC351	42	ISO721M	10	SN65HVD230	18	SN65MLVDS201	42	TL16C2552	16-17	TPS2151	28
CDC391	42	ISO722	10	SN65HVD231	18	SN74GTLPI394	40	TL16C2752	16-17	TPS2155	28
CDC536	42	ISO7220A	10	SN65HVD232	18	SN74GTLPI395	40	TL16C450	16-17	TPS2157	28
CDC5801A	42	ISO7220C	10	SN65HVD233	18	SN74GTLPI2033	40	TL16C451	16-17	TPS2158	28
CDC5806	42	ISO7220M	10	SN65HVD234	18	SN74GTLPI2034	40	TL16C452	16-17	TPS2159	28
CDC582	42	ISO7221A	10	SN65HVD235	18	SN74GTLPI21395	40	TL16C550C	16-17	TPS2204A	34-35
CDC586	42	ISO7221C	10	SN65HVD251	18	SN74GTLPI22033	40	TL16C552A	16-17	TPS2205	34-35
CDC7005	42	ISO7221M	10	SN65LV1023A/1024B	21	SN74GTLPI22034	40	TL16C554A	16-17	TPS2206A	34-35
CDC930	42	ISO722M	10	SN65LVCP22	4-5	SN74GTLPI817	40	TL16C550D	17	TPS2210A	34-35
CDC950	42	LBC170	12	SN65LVCP23	5	SN74GTLPH1612	40	TL16C750	16-17	TPS2211A	34-35
CDC960	42	LBC171	12	SN65LVCP40	5	SN74GTLPH1616	40	TL16C752B	16-17	TPS2212	34-35
CDCD5704	42	LBC172	12	SN65LVDM050	9	SN74GTLPH1627	40	TL16C754B	16-17	TPS2220B	34-35
CDCD5804	42	LBC172A	12	SN65LVDM1676	9	SN74GTLPH1645	40	TL16PCS564B/BLV	17	TPS2221	35
CDCFE706	42	LBC173	12	SN65LVDM179	9	SN74GTLPH1655	40	TL16P1R552	17	TPS2223A	34-35
CDCFE906	42	LBC173A	12	SN65LVDM22	9	SN74GTLPH16612	40	TLK10021	20-21	TPS2224A	35
CDCF5801A	42	LBC174	12	SN65LVDM31	9	SN74GTLPH16912	40	TLK1201AI	20-21	TPS2226A	35
CDCFR83A	42	LBC174A	12	SN65LVDS047	6-7	SN74GTLPH16916	40	TLK1211	20-21	TPS2228	35
CDCLG6010	42	LBC175	12	SN65LVDS048A	6-7	SN74GTLPH16927	40	TLK1501	20-21	TPS2231	34-35
CDCLDV110	4, 42	LBC175A	12	SN65LVDS049	6-7	SN74GTLPH16945	40	TLK1521	20-21	TS3DV416	24
CDCLPV110	42	LBC176	12	SN65LVDS050	6-7	SN74GTLPH306	40	TLK2201AJR	20-21	TS3DV520	24
CDCM1802	42	LBC176A	12	SN65LVDS051	6-7	SN74GTLPH3245	40	TLK2201BI	20-21	TSB14AA1A	37
CDCM1804	42	LBC179	12	SN65LVDS1	6-7	SN74GTLPH32912	40	TLK2208B	20-21	TSB41AB1	37
CDCM7005	42	LBC179A	12	SN65LVDS100	4-5	SN74GTLPH32916	40	TLK2226	20-21	TSB41AB2	37
CDCP1802	42	LBC180	12	SN65LVDS101	4-5	SN74GTLPH32945	40	TLK2501	20-21	TSB41AB3	37
CDCP1803	42	LBC182	12	SN65LVDS104	42	SN74VMEH22501	41	TLK2521	20-21	TSB41BA3B	37
CDCR61A	42	LBC184	12	SN65LVDS105	42	SN75150	14	TLK2701	20-21	TSB41LV04A	37
CDCR83A	42	LT1030	15	SN65LVDS1050	6-7	SN75154	15	TLK2711	20-21	TSB41LV06A	37
CDCU2A877	42	MAX202	14	SN65LVDS108	42	SN75155	14	TLK3101	20-21	TSB81BA3D	37-38
CDCU855	42	MAX202E	14	SN65LVDS109	42	SN751701	15	TLK3104SA	20-21	TUSB1105	26
CDCU877A	42	MAX207	14	SN65LVDS116	42	SN75185	14	TLK3104SC	20-21	TUSB1106	26
CDCUA855	42	MAX207E	14	SN65LVDS117	42	SN75186	15	TLK3114SC	20-21	TUSB2036	26
CDCUA877	42	MAX208	14	SN65LVDS122	4-5	SN75188	14	TLK3118	20-21	TUSB2046B	26
CDCV304	42	MAX208E	14	SN65LVDS16/17	5	SN75189	15	TLK4015	20-21	TUSB2077A	26
CDCV850	42	MAX211	14	SN65LVDS179	6-7	SN75189A	15	TLK4120	20-21	TUSB2136	26
CDCV855	42	MAX211E	14	SN65LVDS18/19	5	SN75196	14	TLK4250	20-21	TUSB2551	26
CDCV857B	42	MAX213	13-14	SN65LVDS180	6-7	SN752232	15	TMDS141	24	TUSB3210	26
CDCV877/A	42	MAX222	14	SN65LVDS2	6-7	SN75240	26	TMDS341A	24	TUSB3410	25-26
CDCVF111	42	MAX232	14	SN65LVDS20	5	SN75C1154	15	TMDS442	24	TUSB5052	26
CDCVF2310	42	MAX232E	13-14	SN65LVDS22	6-7	SN75C1406	15	TPPM0301/2	35	TUSB6020	26
CDCVF2505	42	MAX3221	14	SN65LVDS250	5, 42	SN75C185	15	TPPM0303	35	TUSB6250	26
CDCVF25081	42	MAX3221E	14	SN65LVDS301	19	SN75C188	15	TPS2010A	34-35	UA9636A	15
CDCVF25084	42	MAX3222	15	SN65LVDS302	19	SN75C189	15	TPS2011A	34-35	UC5170C	15
CDCVF2509A	42	MAX3222E	14	SN65LVDS303	19	SN75C189A	15	TPS2012A	34-35	UC5180C	15
CDCVF2510A	42	MAX3223	14	SN65LVDS304	19	SN75C198	15	TPS2013A	34-35	UC5181C	15
CDCVF857	42	MAX3223E	14	SN65LVDS305	19	SN75C23243	14	TPS2020/30	27-28, 34-35	XIO1100	29, 32
EPON	20-21	MAX3227E	14	SN65LVDS306	19	SN75C3221	14	TPS2021/31	27-28, 34-35	XIO2000A	29-30
GD65232	15	MAX3232	14	SN65LVDS31	6-7	SN75C3221E	14	TPS2022/32	28, 35	XIO2200A	29, 31
GD75232	15	MAX3232E	14	SN65LVDS32	6-7	SN75C3222	15	TPS2022/32/61/65	27	XIO3130	29, 31
GD75323	15	MAX3237E	14	SN65LVDS33	5	SN75C3222E	14	TPS2023/33	27-28, 34-35		
HVD05	12	MAX3238	14	SN65LVDS34	5	SN75C3223	14	TPS2024/34	27-28, 35		
HVD06	12	MAX3238E	14	SN65LVDS348	5	SN75C3223E	14	TPS2041B/51B	27-28, 35		
HVD07	12	MAX3243	13-14	SN65LVDS3486	6-7	SN75C3232	14	TPS2042B/52B	27-28, 34-35		
HVD08	12	MAX3243E	13-14	SN65LVDS3487	6-7	SN75C3232E	14	TPS2043B/53B	27-28, 35		
HVD10	12	MAX3318	14	SN65LVDS352	5	SN75C3238	14	TPS2044B/54B	27-28, 34-35		
HVD11	12	MAX3318E	14	SN65LVDS386	4, 6-7	SN75C3243	14	TPS2045A/55A	27-28, 34-35		
HVD1176	12	MAX3386E	14	SN65LVDS387	4, 6-7	SN75LBC187	15	TPS2046B/56A	27-28, 34-35		
HVD12	12	MC1488	15	SN65LVDS388A	6-7	SN75LBC241	15	TPS2047B/57A	27-28, 34-35		
HVD179	12	MC1489	15	SN65LVDS389	6-7	SN75LP1185	14	TPS2048A/58A	27-28, 34-35		
HVD20	12	MC1489A	15	SN65LVDS390	6-7	SN75LP196	14	TPS2060/4	28, 35		
HVD21	12	MLVD128	8, 42	SN65LVDS391	6-7	SN75LPE185	14	TPS2061/5	28, 35		
HVD22	12	MLVD129	42	SN65LVDS93/94	20-21	SN75LV4737A	14	TPS2062/6	28, 35		

TI Worldwide Technical Support

Internet

TI Semiconductor Product Information Center Home Page

support.ti.com

TI Semiconductor KnowledgeBase Home Page

support.ti.com/sc/knowledgebase

Product Information Centers

Americas

Phone +1(972) 644-5580

Fax +1(972)927-6377

Internet support.ti.com/sc/pic/americas.htm

Europe, Middle East, and Africa

Phone

Belgium (English) +32 (0) 27 45 54 32

Finland (English) +358 (0) 9 25173948

France +33 (0) 1 30 70 11 64

Germany +49 (0) 8161 80 33 11

Israel (English) 180 949 0107

Italy 800 79 11 37

Netherlands (English) +31 (0) 546 87 95 45

Russia +7 (4) 95 98 10 701

Spain +34 902 35 40 28

Sweden (English) +46 (0) 8587 555 22

United Kingdom +44 (0) 1604 66 33 99

Fax +49 (0) 8161 80 2045

Internet support.ti.com/sc/pic/euro.htm

Japan

Fax

International +81-3-3344-5317

Domestic 0120-81-0036

Internet

International support.ti.com/sc/pic/japan.htm

Domestic www.tij.co.jp/pic

Asia

Phone

International +886-2-23786800

Domestic Toll Free Number

Australia 1-800-999-084

China 800-820-8682

Hong Kong 800-96-5941

India +91-80-41381665 (Toll)

Indonesia 001-803-8861-1006

Korea 080-551-2804

Malaysia 1-800-80-3973

New Zealand 0800-446-934

Philippines 1-800-765-7404

Singapore 800-886-1028

Taiwan 0800-006800

Thailand 001-800-886-0010

Fax +886-2-2378-6808

Email tiasia@ti.com or ti-china@ti.com

Internet support.ti.com/sc/pic/asia.htm

Safe Harbor Statement

This publication may contain forward-looking statements that involve a number of risks and uncertainties. These "forward-looking statements" are intended to qualify for the safe harbor from liability established by the Private Securities Litigation Reform Act of 1995. These forward-looking statements generally can be identified by phrases such as TI or its management "believes," "expects," "anticipates," "foresees," "forecasts," "estimates" or other words or phrases of similar import. Similarly, such statements herein that describe the company's products, business strategy, outlook, objectives, plans, intentions or goals also are forward-looking statements. All such forward-looking statements are subject to certain risks and uncertainties that could cause actual results to differ materially from those in forward-looking statements. Please refer to TI's most recent Form 10-K for more information on the risks and uncertainties that could materially affect future results of operations. We disclaim any intention or obligation to update any forward-looking statements as a result of developments occurring after the date of this publication.

Important Notice: The products and services of Texas Instruments Incorporated and its subsidiaries described herein are sold subject to TI's standard terms and conditions of sale. Customers are advised to obtain the most current and complete information about TI products and services before placing orders. TI assumes no liability for applications assistance, customer's applications or product designs, software performance, or infringement of patents. The publication of information regarding any other company's products or services does not constitute TI's approval, warranty or endorsement thereof.

Technology for Innovators, the black/red banner, PanelBus, FlatLink, MicroStar Junior, PowerPAD, DLP, MicroStar, OEC and TI-OPC are trademarks of Texas Instruments. All other trademarks are the property of their respective owners.

© 2006 Texas Instruments Incorporated

♻️ Printed in U.S.A. by (Printer, City, State), on recycled paper

D062706

Texas Instruments Incorporated

14950 FAA Blvd.

Fort Worth, TX 76155-9950

Address service requested

PRSR STD
U.S. POSTAGE
PAID
DALLAS, TEXAS
PERMIT NO. 2758

IMPORTANT NOTICE

Texas Instruments Incorporated and its subsidiaries (TI) reserve the right to make corrections, modifications, enhancements, improvements, and other changes to its products and services at any time and to discontinue any product or service without notice. Customers should obtain the latest relevant information before placing orders and should verify that such information is current and complete. All products are sold subject to TI's terms and conditions of sale supplied at the time of order acknowledgment.

TI warrants performance of its hardware products to the specifications applicable at the time of sale in accordance with TI's standard warranty. Testing and other quality control techniques are used to the extent TI deems necessary to support this warranty. Except where mandated by government requirements, testing of all parameters of each product is not necessarily performed.

TI assumes no liability for applications assistance or customer product design. Customers are responsible for their products and applications using TI components. To minimize the risks associated with customer products and applications, customers should provide adequate design and operating safeguards.

TI does not warrant or represent that any license, either express or implied, is granted under any TI patent right, copyright, mask work right, or other TI intellectual property right relating to any combination, machine, or process in which TI products or services are used. Information published by TI regarding third-party products or services does not constitute a license from TI to use such products or services or a warranty or endorsement thereof. Use of such information may require a license from a third party under the patents or other intellectual property of the third party, or a license from TI under the patents or other intellectual property of TI.

Reproduction of information in TI data books or data sheets is permissible only if reproduction is without alteration and is accompanied by all associated warranties, conditions, limitations, and notices. Reproduction of this information with alteration is an unfair and deceptive business practice. TI is not responsible or liable for such altered documentation.

Resale of TI products or services with statements different from or beyond the parameters stated by TI for that product or service voids all express and any implied warranties for the associated TI product or service and is an unfair and deceptive business practice. TI is not responsible or liable for any such statements.

Following are URLs where you can obtain information on other Texas Instruments products and application solutions:

Products		Applications	
Amplifiers	amplifier.ti.com	Audio	www.ti.com/audio
Data Converters	dataconverter.ti.com	Automotive	www.ti.com/automotive
DSP	dsp.ti.com	Broadband	www.ti.com/broadband
Interface	interface.ti.com	Digital Control	www.ti.com/digitalcontrol
Logic	logic.ti.com	Military	www.ti.com/military
Power Mgmt	power.ti.com	Optical Networking	www.ti.com/opticalnetwork
Microcontrollers	microcontroller.ti.com	Security	www.ti.com/security
Low Power Wireless	www.ti.com/lpw	Telephony	www.ti.com/telephony
		Video & Imaging	www.ti.com/video
		Wireless	www.ti.com/wireless

Mailing Address: Texas Instruments
Post Office Box 655303 Dallas, Texas 75265